

SONOROUS[®] | FURNITURE

Sonorous provides audio&video related products with focus on quality, functionality and aesthetics. Founded in 2004, a solid position and reputation worldwide has been built up over the years. Now represented worldwide in more than 50 countries via strong partnerships with a global network of distributors.

Our products are engineered to meet the demanding needs of today's electronics and represent an attentive monitoring of market trends and changes. Continuous research into materials and finishes has been distinguishing characteristics of Sonorous.



AUDIOVISUAL FURNITURE

INDEX

WOOD SERIES

| | |
|------------------|-------|
| STUDIO SERIES | 8-15 |
| RETRO SERIES | 16-17 |
| MOOD SERIES | 18-23 |
| LB SERIES | 24-27 |
| TRN & TRD SERIES | 28-31 |

GLASS & METAL SERIES

| | |
|------------|-------|
| PL SERIES | 32-45 |
| NEO SERIES | 46-53 |

SOUND SYSTEMS

| | |
|---------------|-------|
| SOUND SYSTEMS | 54-59 |
|---------------|-------|

PRO SERIES

| | |
|------------|-------|
| PRO SERIES | 60-61 |
|------------|-------|

STUDIO SERIES

- FLAP DOOR WITH PUSH TO OPEN SYSTEM
- TOP PANEL TEMPERED GLASS
- FRONT DOOR WITH GLASS, WOOD DECORS OR FABRIC
- CABINET WITH BASE OR WALL HANGING (WALL HANGING ONLY FOR ST 110-160)
- ADJUSTABLE SHELVES FOR AV EQUIPMENT (ONLY FOR ST 160-161-200)
- EASY CABLE ACCESS BETWEEN SHELVES AND SECTIONS
- HIDDEN INFRARED REPEATER SYSTEM, REMOTE CONTROL FOR COMPONENTS BEHIND CABINET DOORS
- IR FRIENDLY FRONT GLASS (ONLY AVAILABLE FOR "I" MODEL)
- OPTIONAL BRACKET (EXCEPT ST 200)
- FULLY ASSEMBLED (A) OR DISASSEMBLED (D)
- ACOUSTIC FABRIC FOR AUDIO DEVICES INCLUDING CENTER SPEAKERS, SOUNDBARS
- ACOUSTIC PERFORATED DOOR FOR AUDIO DEVICES INCLUDING CENTER SPEAKERS, SOUNDBARS (ONLY FOR ST 200)

ST 110 ST 160 ST 200 ST 261 ST 361
 ST 111 ST 161 ST 260 ST 360 ST 362 ST 363

BODY COLORS

WHT-WHITE



BLK-BLACK

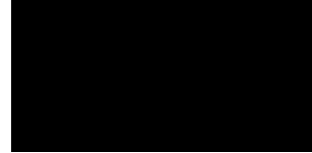

F- FLAP
 I- IR FRIENDLY GLASS
 T- TEXTILE
 P- PERFORATED(only for ST200)

DOOR OPTIONS AND COLORS

WOOD DECOR

CWN-CASTELLO WALNUT



VIC-VICTORIA



OAK-OAK



BNW-BLACK NORTH WOOD



GNW-GREY NORDIC WOOD



LOAK-LIGHT OAK



PERFORATED COLORS

WHT-WHITE



BLK-BLACK



GLASS COLORS

WHT-WHITE

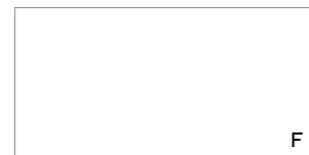

BLK-BLACK

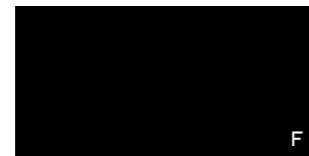

HOW (I) GLASS LOOKS

I-BLK-BLACK



I-WHT-WHITE

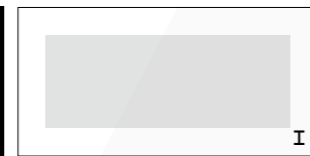

TEXTILE

GRY-GREY

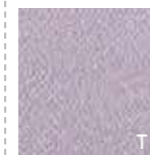

BLK-BLACK

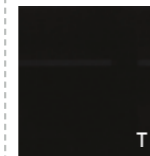

OLV-OLIVE



NAVY-NAVY

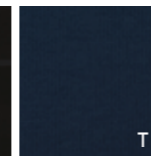

IRN-IRON

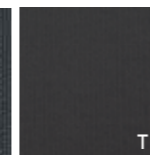

BRD-BORDEAUX



STA 200P-WHT-WHT-BS

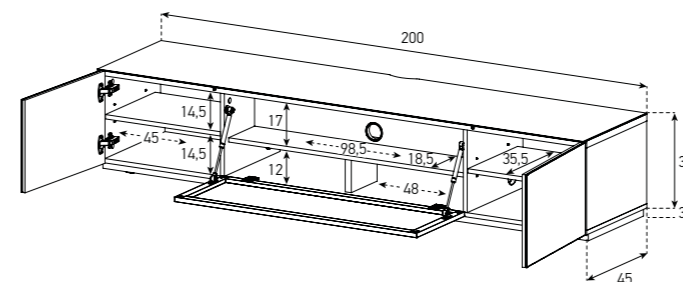

- MAX TOP LOAD
100 KG
- IDEAL SCREEN SIZE
85"







STA 360F-WHT-GNW-SL

STA 110F-WHT-WHT-BS

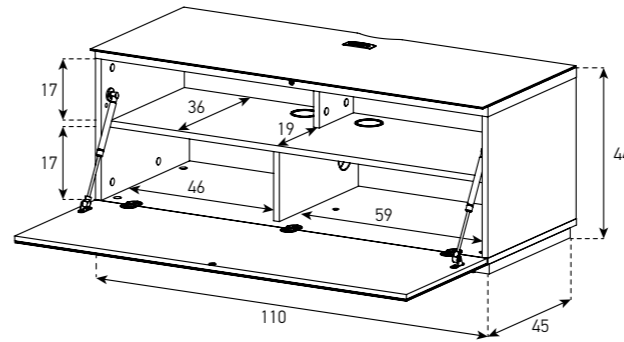
-  MAX TOP LOAD
60 KG
-  IDEAL SCREEN SIZE
52"



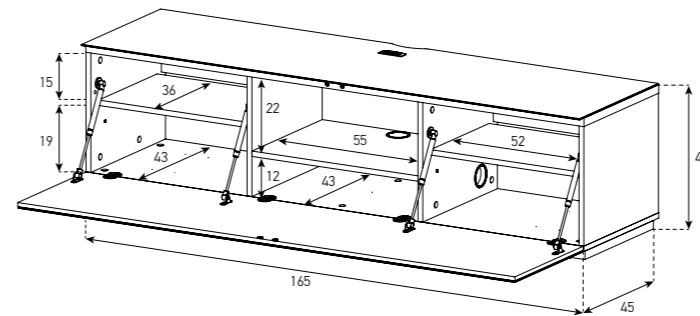

STA 160F-BLK-CWN-BS

-  MAX TOP LOAD
60 KG
-  IDEAL SCREEN SIZE
70"





STA 200P-WHT-WHT-BS

STA 260T-WHT-BLK-BS

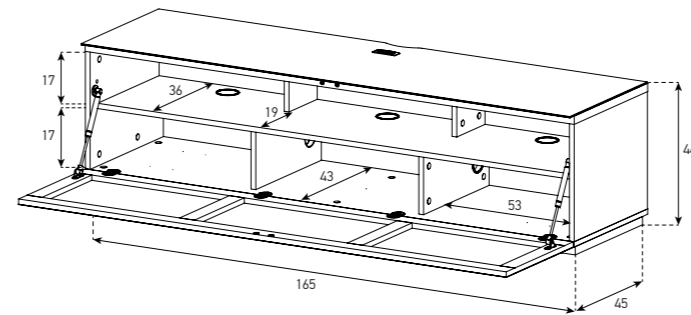
-  MAX TOP LOAD
60 KG
-  IDEAL SCREEN SIZE
70"



STA 360I-WHT-WHT-SL

-  MAX TOP LOAD
60 KG
-  IDEAL SCREEN SIZE
70"

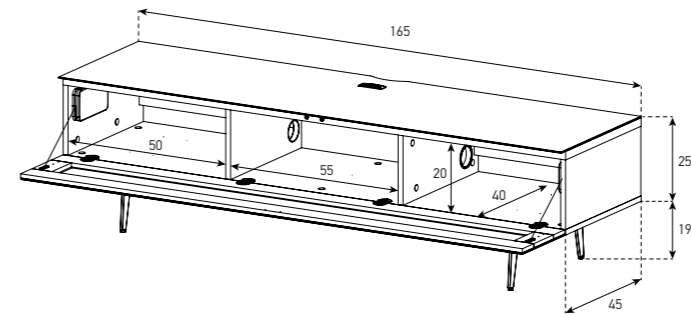

STA 362I-WHT-BLK-SL

- MAX TOP LOAD
60 KG
- IDEAL SCREEN SIZE
76"

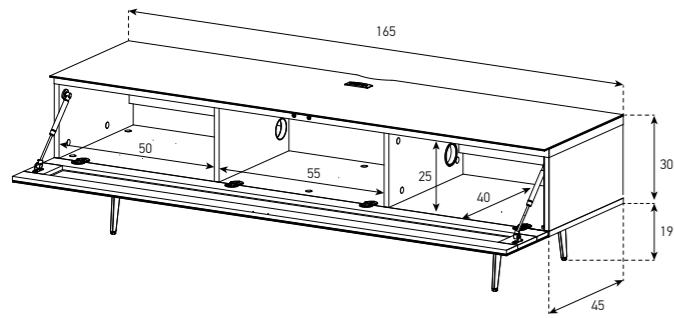

STA 361F-BLK-BLK-SL

- MAX BRACKET LOAD
50 KG
- IDEAL SCREEN SIZE
68"

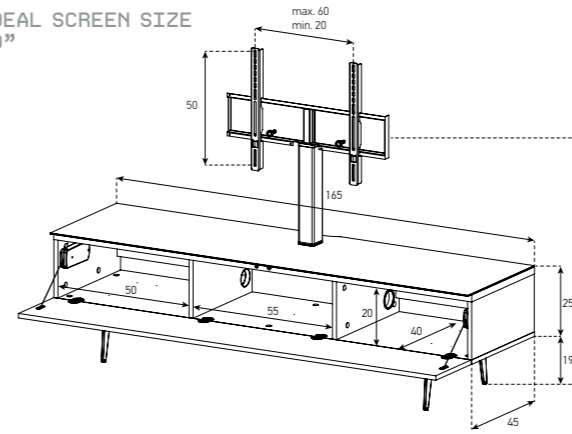

45°



STA 111T-BLK-OLV-BS

- MAX BRACKET LOAD
50 KG
- IDEAL SCREEN SIZE
52"

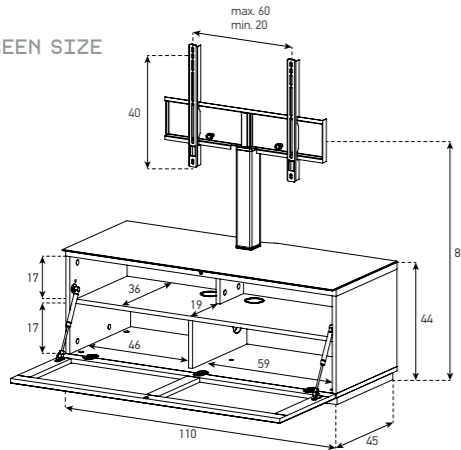

45°



STA 363F-BLK-BNW-SL

- MAX BRACKET LOAD
50 KG
- IDEAL SCREEN SIZE
68"

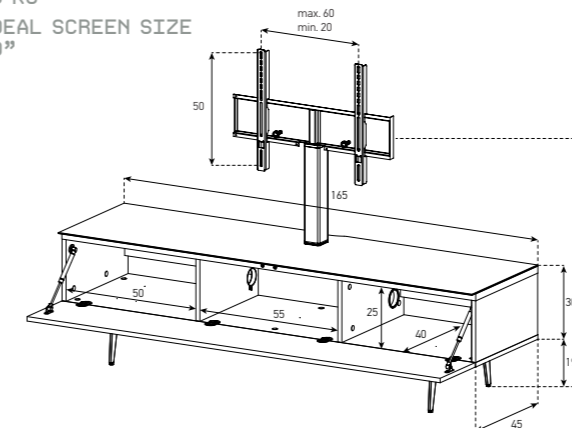

45°



STA 161I-WHT-WHT-BS

- MAX BRACKET LOAD
50 KG
- IDEAL SCREEN SIZE
68"

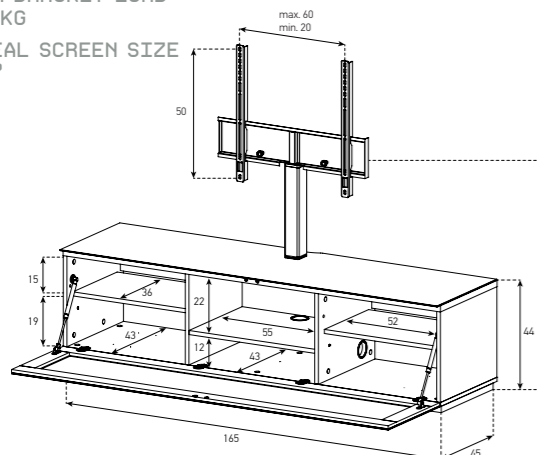

45°



Bracket Kit ST-ADP-SLV-4060

- MAX BRACKET LOAD
50 KG
- IDEAL SCREEN SIZE
68"

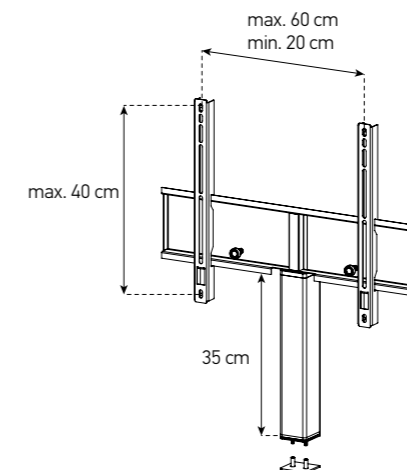

STA 261T-BLK-BLK-BS

- MAX BRACKET LOAD
50 KG
- IDEAL SCREEN SIZE
68"

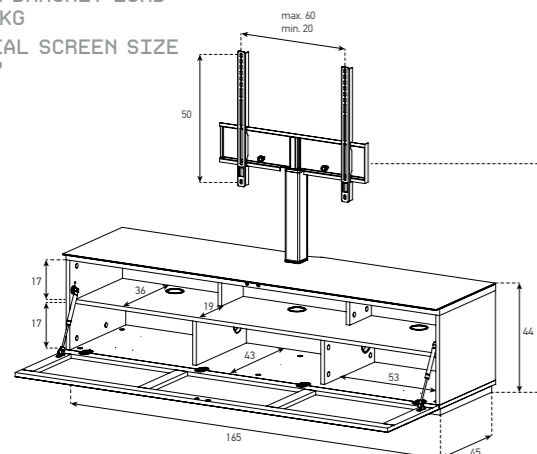

45°



Bracket Kit ST-ADP-HBLK-5060

- MAX BRACKET LOAD
50 KG
- IDEAL SCREEN SIZE
68"

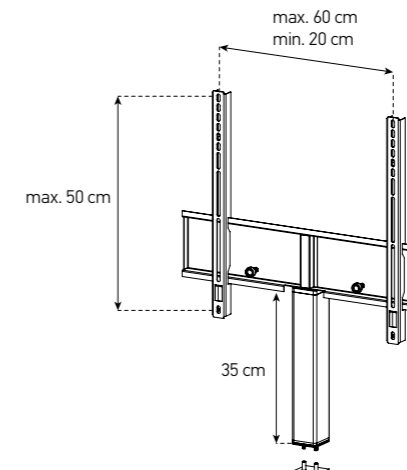

STA 110I-BLK-BLK-WL



STA 110F-BLK-BLK-BS



CODE SAMPLE

STA 110F-WHT-WHT-BS

1 2 3 4 5 6 7

- 1- STUDIO SERIES
- 2- ASSEMBLE OPTION

- (A) - ASSEMBLED
- (D) - DISASSEMBLED

- 3- MODEL

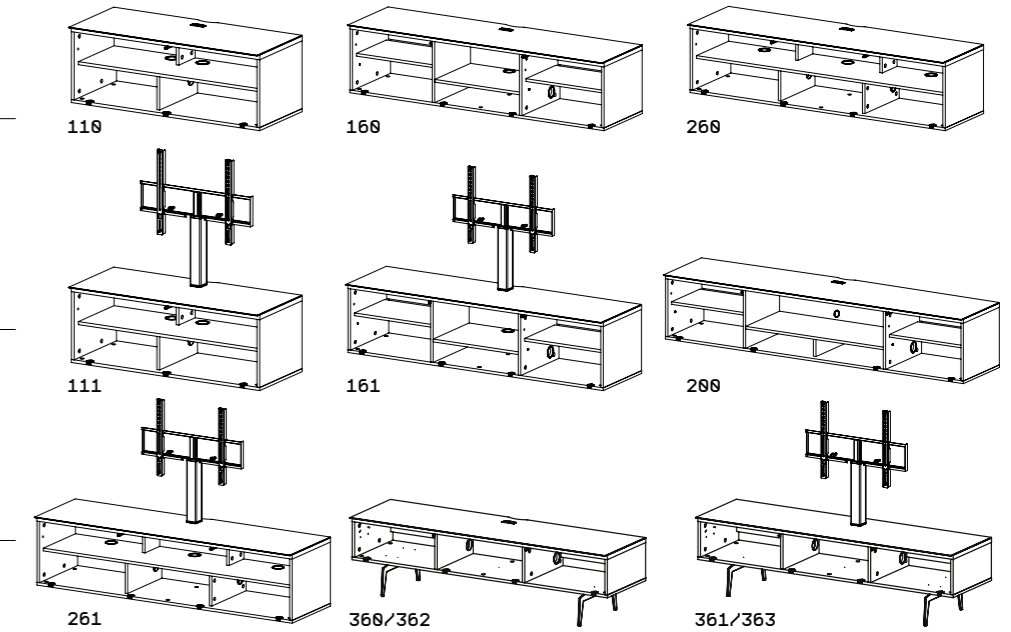

- 4- DOOR OPTION

- (F) - FLAP (NOT APPLICABLE TO 260/261 MODELS)
- (I) - IR FRIENDLY (GLASS)
- (T) - TEXTILE
- (P) - PERFORATED (ONLY FOR ST 200)

- 5- BODY COLOR

- (BLK) - BLACK
- (WHT) - WHITE

- 6- DOOR COLOR

- (WHT) - WHITE
- (BLK) - BLACK
- (GNW) - GREY NORDIC WOOD
- (CWN) - CASTELLO WALNUT
- (OAK) - OAK
- (BNW) - BLACK NORTH WOOD
- (VIC) - VICTORIA
- (LOAK) - LIGHT OAK
- (GRY) - GREY
- (OLV) - OLIVE
- (IRN) - IRON
- (BRD) - BORDEAUX
- (NYV) - NAVY

APPLICABLE DOOR OPTIONS

- (F) (I) (P)
- (F) (I) (T) (P)
- (F)
- (F)
- (F)
- (F)
- (F)
- (F)
- (F)
- (T)
- (T)
- (T)
- (T)
- (T)

- 7- FLOOR/WALL OPTION

- (BS) - BASE
- (WL) - WALL HANGING (EXCEPT 300 SERIES AND ST 200)
- (BW) - BASE & WALL HANGING
- (SL) - STEEL LEGS (ONLY AVAILABLE FOR 300 SERIES)

RETRO SERIES

- Contemporary design to complement your décor
- Sturdy construction to support large screen TVs up to 70"
- Dimensions: 140/180 cm X 54 cm X 40 cm
- Max. Top load : 60 kg
- Optimum dimension to accommodate your AV equipment
- Conical solid wood feet
- Two sliding doors with several uni-decor colors
- Cable management system
- Adjustable shelves to optimize spaces for AV equipments



RTR 140
RTR 180

BODY COLORS

BLK-BLACK



WHT-WHITE



VIC-VICTORIA



DOOR COLORS

GBLK-GLOSSY BLACK



CWN-CASTELLO WALNUT



OAK-OAK



GWHT-GLOSSY WHITE



BNW-BLACK NORTH WOOD



LOAK-LIGHT OAK

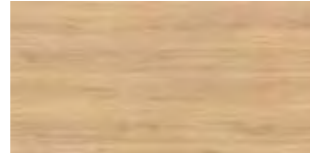

VIC-VICTORIA



GNW-GREY NORDIC WOOD



RTR 140-BLK-BNW



MAX TOP LOAD
60 KG



IDEAL SCREEN SIZE
60"

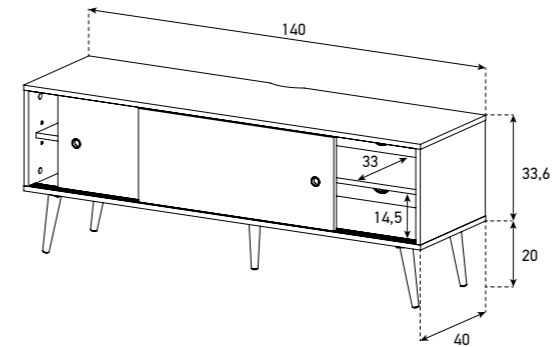

RTR 180-WHT-VIC



MAX TOP LOAD
60 KG



IDEAL SCREEN SIZE
70"

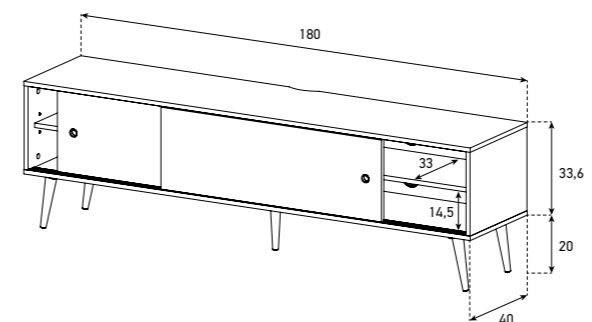

MOOD SERIES

- TEMPERED GLASS WITH FLAT POLISHED EDGE
- ANODIZED OR POWDER COATED ALUMINIUM PROFILES IN BACK COLUMN AND LEGS
- MELAMINE FACED WOOD OR NON-SCRATCH HIGH GLOSS FINISHING CABINETS
- CABINET FLAP FOR A/V EQUIPMENT
- CABINET FLAP FOR DVD HOLDER
- CABINET DRAWER WITH "SILENT STOP"
- INTEGRATED CABLE MANAGEMENT SYSTEM
- HIDDEN CASTERS
- (24°) SWIVEL SYSTEM
- ADJUSTABLE HEIGHT FOR BRACKET (+/- 75 MM)

- | | | | |
|---------|---------|---------|---------|
| MD 8140 | MD 8340 | MD 9140 | MD 9540 |
| MD 8143 | MD 8540 | MD 9240 | |
| MD 8240 | MD 9135 | MD 9340 | |

GLASS COLORS

C-CLEAR



B-BLACK



WOOD FINISHING

BLK-BLACK



CWN-CASTELLO WALNUT



VIC-VICTORIA



ALUMINIUM FINISHING

INX-INOX



HBLK-HIGH GLOSS BLACK



WHT-WHITE



GNW-GREY NORDIC WOOD



BNW-BLACK NORTH WOOD



OAK-OAK



LOAK-LIGHT OAK



RED-RED

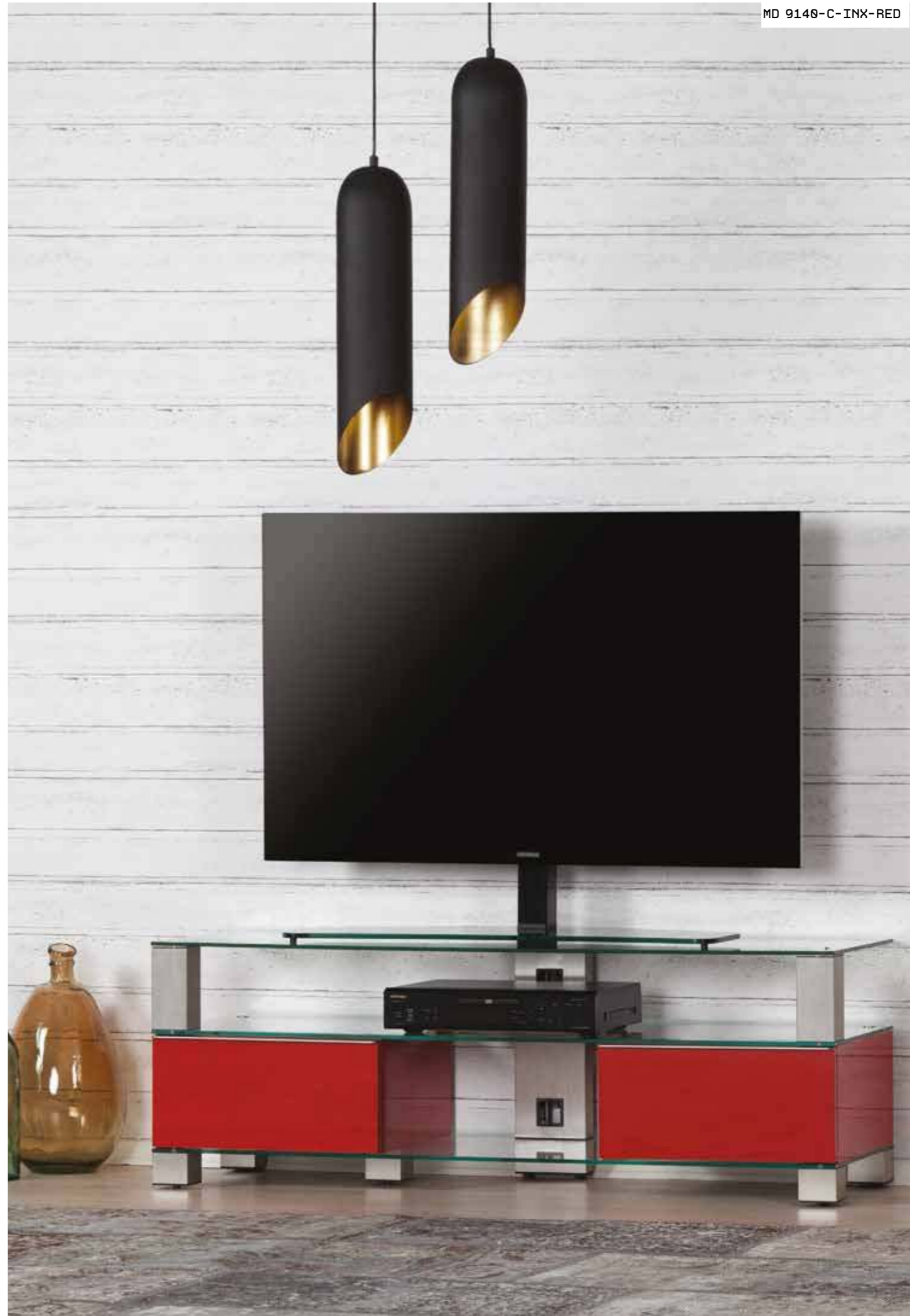

MD 8140-C-INX-WHT

- MAX BRACKET LOAD
50 KG
- IDEAL SCREEN SIZE
60"

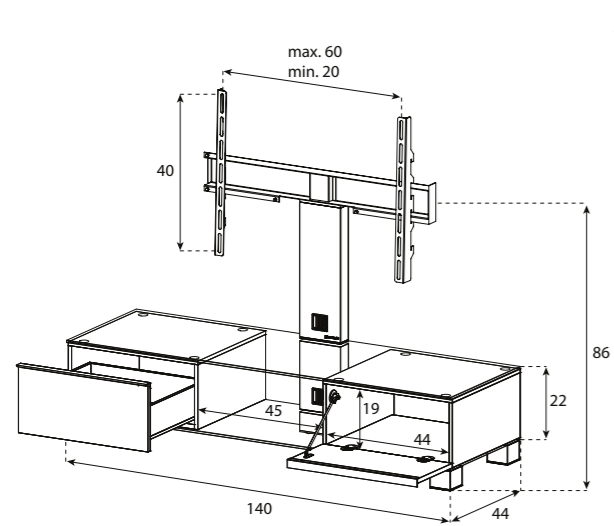

MD 8340-B-INX-BLK

- MAX BRACKET LOAD
50 KG
- IDEAL SCREEN SIZE
60"

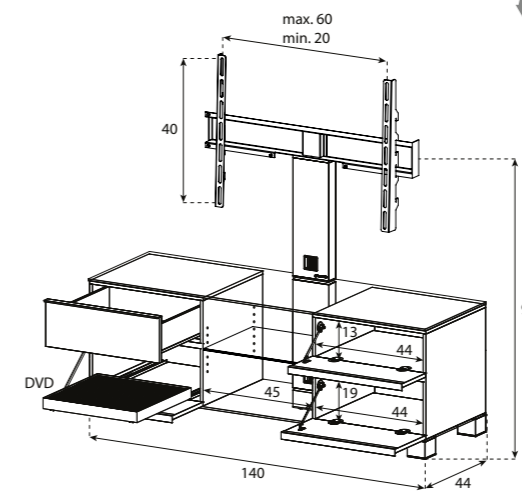

MD 8143-B-HBLK-BLK

- MAX BRACKET LOAD
50 KG
- IDEAL SCREEN SIZE
60"

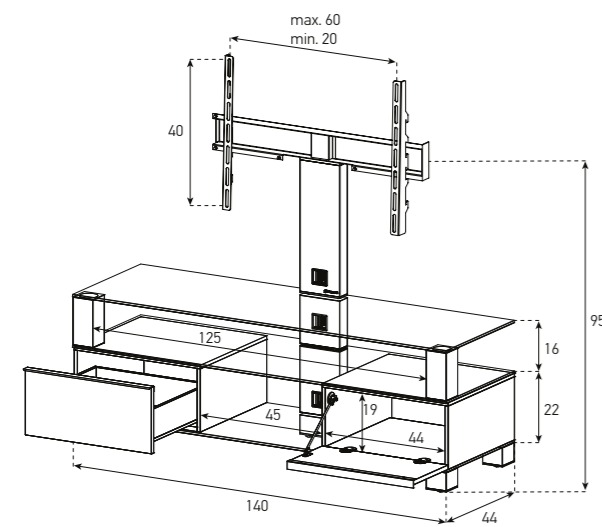

MD 8240-C-INX-RED

- MAX BRACKET LOAD
50 KG
- IDEAL SCREEN SIZE
60"

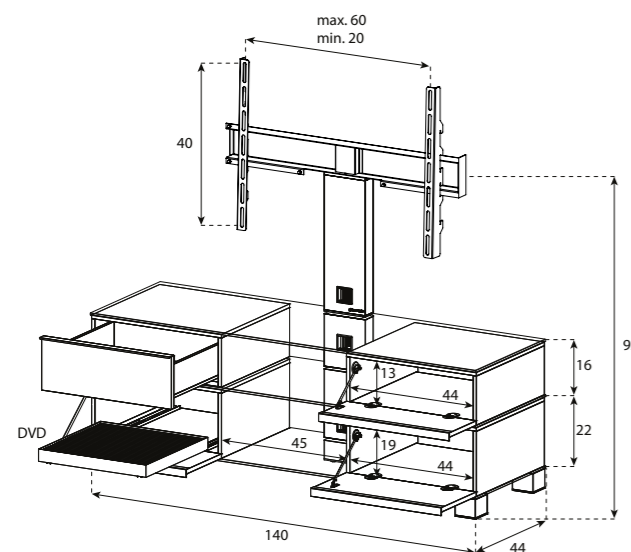

MD 8240-C-INX-WHT



MD 8540-B-INX-GNW

- MAX BRACKET LOAD
50 KG
- IDEAL SCREEN SIZE
60"

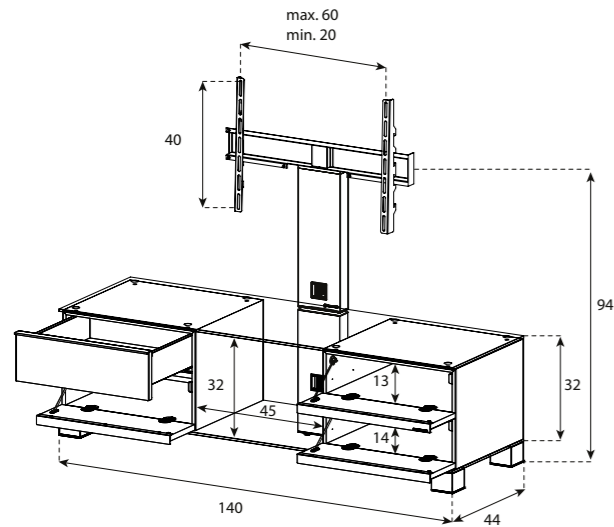

MD 9340-B-INX-BNW

- MAX TOP LOAD
80 KG
- IDEAL SCREEN SIZE
60"

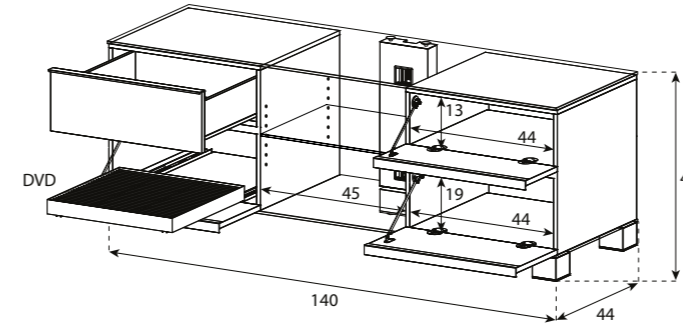

MD 9140-B-HBLK-LOAK

- MAX TOP LOAD
80 KG
- IDEAL SCREEN SIZE
60"

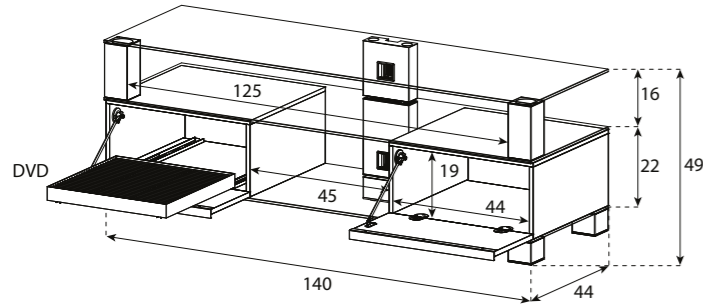

MD 9135-B-HBLK-BLK

- MAX TOP LOAD
50 KG
- IDEAL SCREEN SIZE
50"

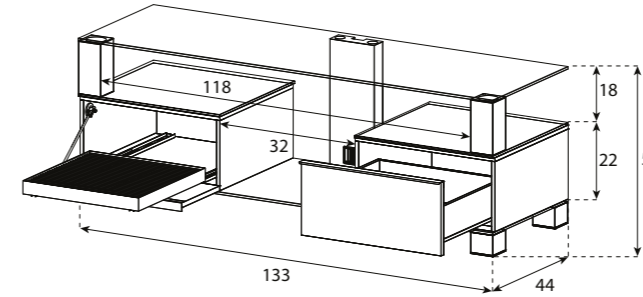

MD 9240-B-INX-LOAK

- MAX TOP LOAD
80 KG
- IDEAL SCREEN SIZE
60"

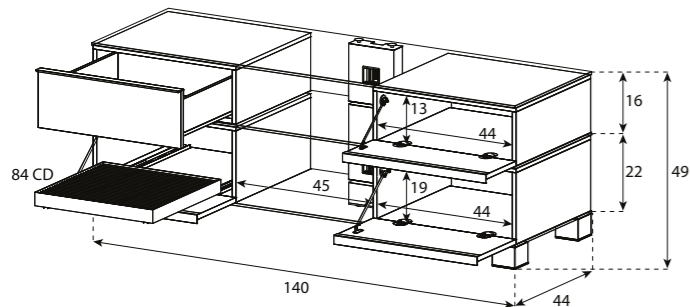

MD 9540-B-INX-CWN

- MAX TOP LOAD
80 KG
- IDEAL SCREEN SIZE
60"

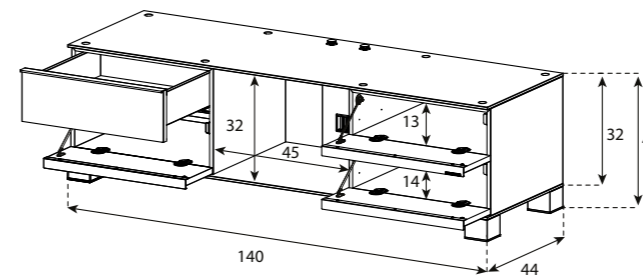

LB SERIES

LB 1620 / LB 1621

TOP PANEL COVERED WITH BLACK TEMPERED GLASS OR WALNUT WOOD DECOR
 TEMPERED GLASS FRONT DOORS, REMOTE CONTROL WORKS THROUGH
 REMOVABLE MIDDLE SHELVES
 MIDDLE DOOR COVERED WITH FABRIC (ONLY FOR LB 1621)
 SHELVES FOR AV EQUIPMENT / SUBWOOFER
 HIDDEN CASTERS

LB 1123 / LB 2120

BLACK TEMPERED GLASS
 DRAWERS WITH PUSH TO OPEN SYSTEM
 HIDDEN CASTERS

LB 1840 / 1540 / 1181

BLACK TOP PANEL COVERED WITH BLACK TEMPERED GLASS
 GLOSSY AND WOOD DECOR FRONT DOORS
 REMOVABLE MIDDLE SHELVES
 DRAWERS WITH PUSH TO OPEN SYSTEM

LB 1123² LB 1620⁴ LB 2120²
 LB 1181⁴ LB 1621⁴
 LB 1540³ LB 1840³

GLASS COLORS

B-BLACK



BODY COLORS

BLK-BLACK

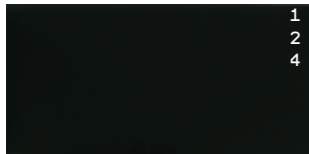

GBLK-GLOSSY BLACK

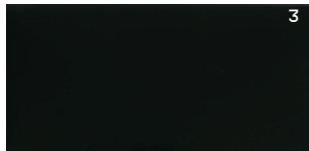

DOOR COLORS

GBLK-GLOSSY BLACK

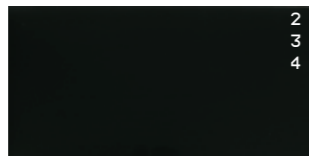

OAK-OAK



LOAK-LIGHT OAK

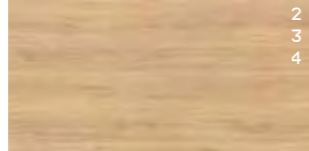

GWHT-GLOSSY WHITE



GNW-GREY NORDIC WOOD



BNW-BLACK NORTH WOOD



CWN-CASTELLO WALNUT



VIC-VICTORIA



LB 1123-B-BLK-GBLK

- MAX BRACKET LOAD
40 KG
- IDEAL SCREEN SIZE
50"

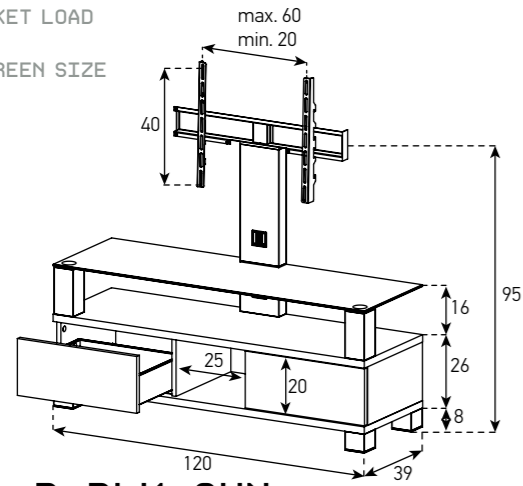

LB 1181-B-BLK-CWN

- MAX TOP LOAD
40 KG
- IDEAL SCREEN SIZE
50"

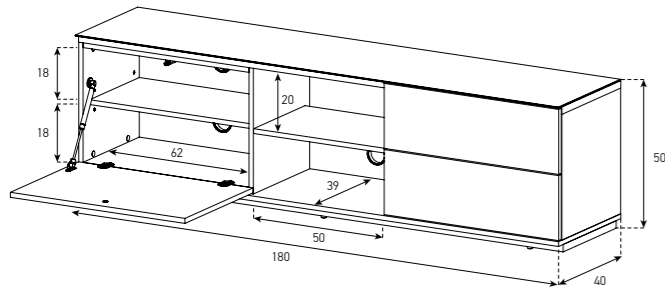

LB 1540-B-BLK-OAK

- MAX TOP LOAD
40 KG
- IDEAL SCREEN SIZE
50"

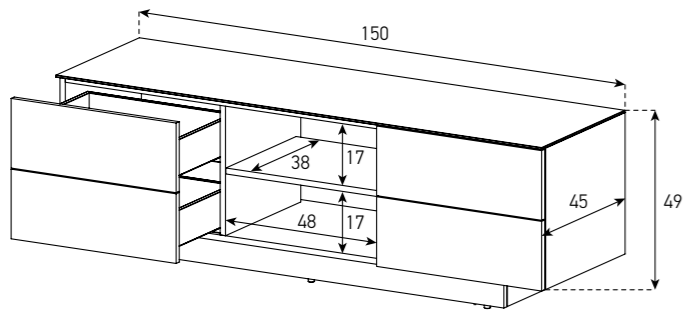

LB 1620-B-BLK

- MAX TOP LOAD
80 KG
- IDEAL SCREEN SIZE
70"

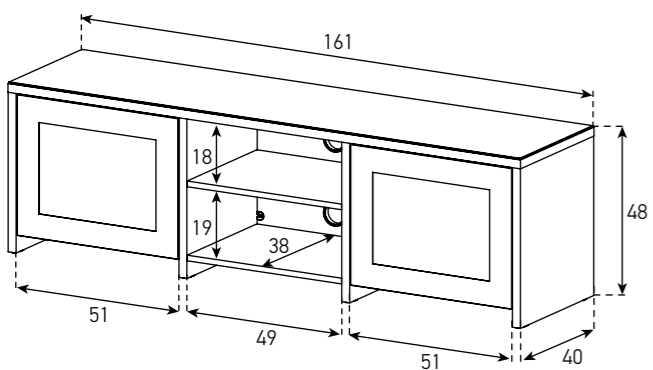

LB 1621-B-BLK

- MAX TOP LOAD
80 KG
- IDEAL SCREEN SIZE
70"

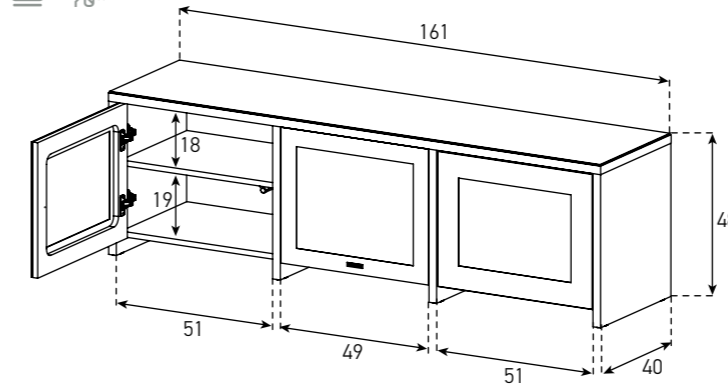

LB 1840-GBLK-GWHT

- MAX TOP LOAD
80 KG
- IDEAL SCREEN SIZE
70"

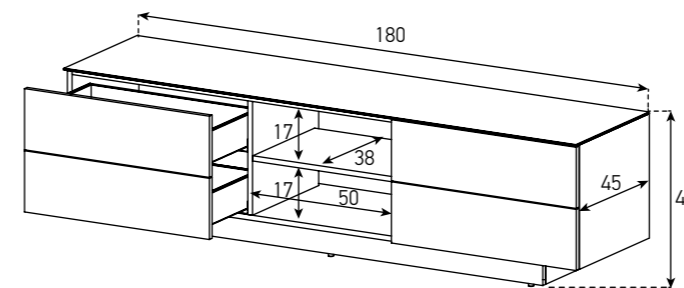

LB 2120-B-BLK-GBLK

- MAX TOP LOAD
50 KG
- IDEAL SCREEN SIZE
50"

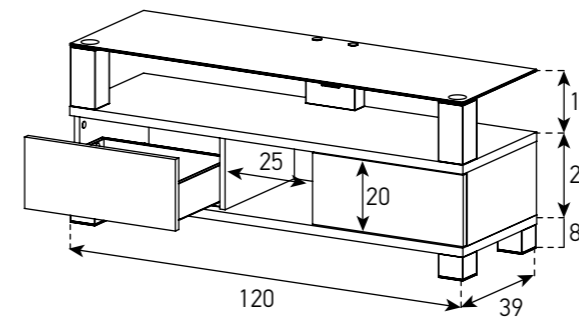

TRN & TRD SERIES

TRN

TOP PANEL BLACK TEMPERED GLASS
WOOD CABINET WITH FLAP DOOR AND/OR DRAWERS
HIDDEN CASTORS
SHELVES FOR A/V EQUIPMENTS

TRD

WOOD CABINET WITH FLAP DOWN OR SIDE OPENING DOORS
SHELVES FOR A/V EQUIPMENTS

TRN 1113¹
TRN 1133¹
TRN 2110¹
TRN 2130¹

TRD 90²
TRD 100²
TRD 120²
TRD 150²



TRN 1113-B-BLK-LOAK

GLASS COLORS

B-BLACK



ALUMINIUM FINISHING

SLV-SILVER



HBLK-HIGH GLOSS BLACK



BODY COLORS

BLK-BLACK



GWHT-GLOSSY WHITE



GBLK-GLOSSY BLACK



DOOR COLORS

GBLK-GLOSSY BLACK

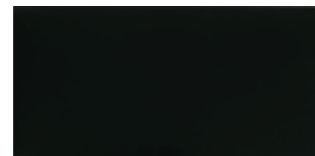

VIC-VICTORIA



CWN-CASTELLO WALNUT



GWHT-GLOSSY WHITE



OAK-OAK



LOAK-LIGHT OAK



BNW-BLACK NORTH WOOD



GNW-GREY NORDIC WOOD



TRD 150-GBLK-GWHT

TRN 1113-B-BLK-GWHT

- MAX BRACKET LOAD
50 KG
- IDEAL SCREEN SIZE
46"

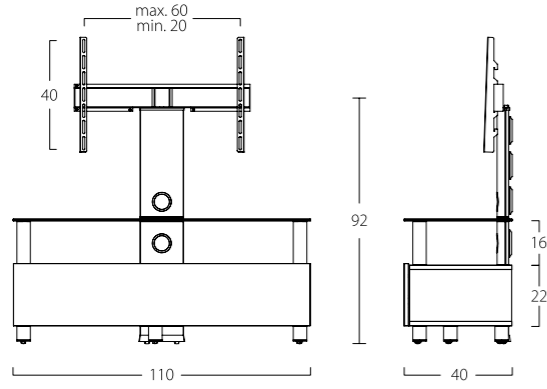

TRD 90-GBLK-VIC

- MAX LOAD
50 KG
- IDEAL SCREEN SIZE
42"

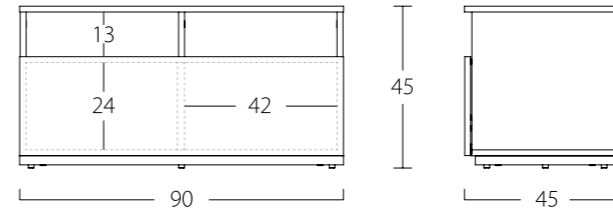

TRN 1133-B-BLK-GNW

- MAX BRACKET LOAD
50 KG
- IDEAL SCREEN SIZE
55"

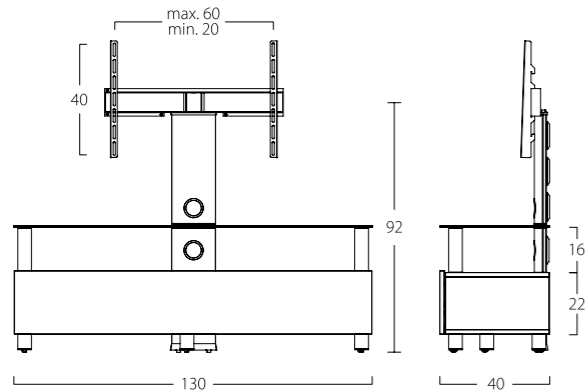

TRD 100-GBLK-OAK

- MAX LOAD
50 KG
- IDEAL SCREEN SIZE
50"

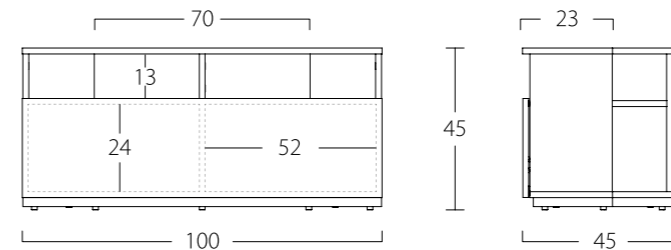

TRN 2110-B-BLK-BNW

- MAX LOAD
50 KG
- IDEAL SCREEN SIZE
46"

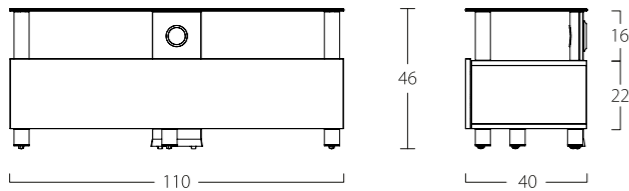

TRD 120-GBLK-CWN

- MAX LOAD
50 KG
- IDEAL SCREEN SIZE
55"

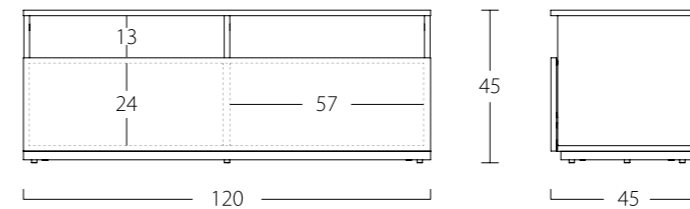

TRN 2130-B-BLK-CWN

- MAX LOAD
50 KG
- IDEAL SCREEN SIZE
55"

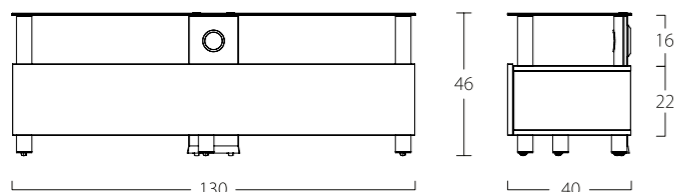

TRD 150-GWHT-LOAK

- MAX LOAD
50 KG
- IDEAL SCREEN SIZE
60"

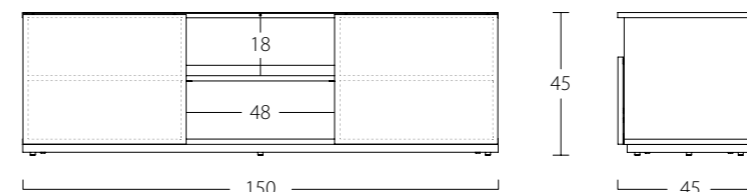

PL SERIES

- TEMPERED GLASS WITH FLAT POLISHED EDGE
- ELLIPTICAL OR RECTANGLE SHAPED ALUMINIUM
- INTEGRATED CABLE MANAGEMENT SYSTEM
- HIDDEN CASTERS
- SWIVEL SYSTEM
- ADJUSTABLE HEIGHT FOR BRACKET

PL 2000⁴ PL 2335⁴ PL 2500³ PL 2611⁴ PL 2810² PL 3400³
 PL 2100⁴ PL 2344⁴ PL 2510³ PL 2620⁴ PL 3100⁴ PL 3405³
 PL 2130⁴ PL 2345⁴ PL 2511³ PL 2700¹ PL 3110⁴ PL 3410³
 PL 2200⁴ PL 2400³ PL 2515³ PL 2710¹ PL 3115⁴ PL 3415³
 PL 2310⁴ PL 2430³ PL 2610⁴ PL 2800² PL 3150⁴

ALUMINIUM COLORS

SLV-SILVER



HBLK-HIGH GLOSS BLACK



INX-INOX



GLASS COLORS

C-CLEAR



B-PIANOBLACK



WHT-WHITE

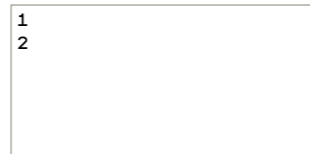

RED-RED



PL2700-PL2710-PL2800-PL2810 GLASS COLOR OPTIONS

BLK-BLACK

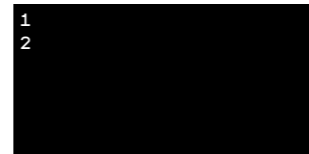

GRP-GRAPHITE

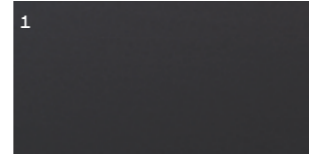

PL 2000-C-SLV

- MAX BRACKET LOAD
60 KG
- IDEAL SCREEN SIZE
60"

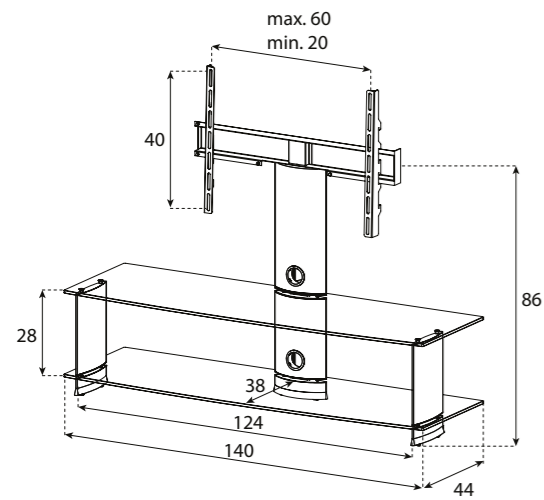

35°



PL 2100-B-SLV

- MAX BRACKET LOAD
50 KG
- IDEAL SCREEN SIZE
50"

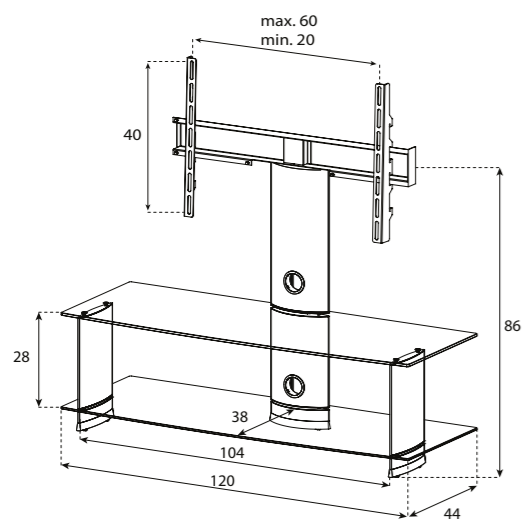

35°



PL 2130-B-HBLK

- MAX BRACKET LOAD
50 KG
- IDEAL SCREEN SIZE
50"

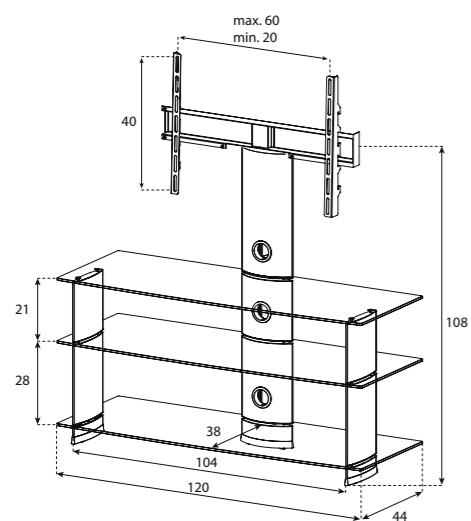

35°



PL 2200-B-SLV

- MAX BRACKET LOAD
30 KG
- IDEAL SCREEN SIZE
40"

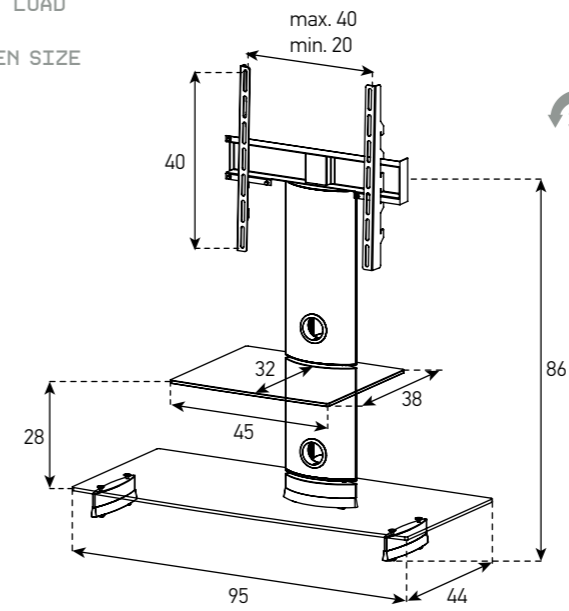

35°



PL 2400-B-INX

- MAX BRACKET LOAD
50 KG
- IDEAL SCREEN SIZE
50"

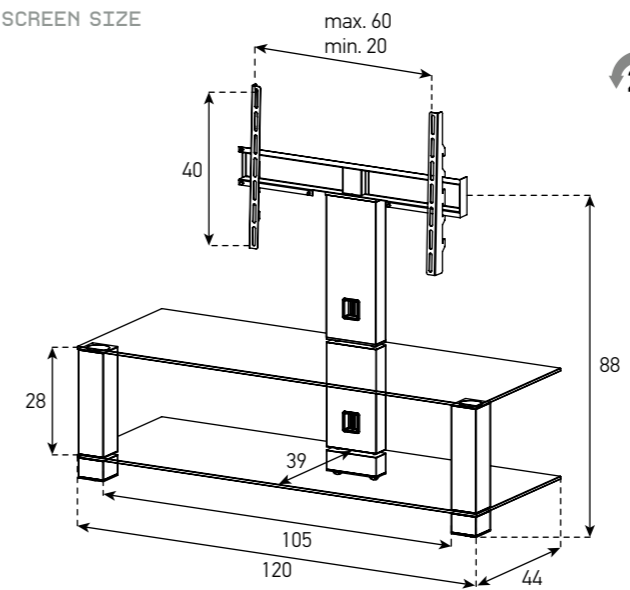

24°



PL 2430-B-INX

- MAX BRACKET LOAD
50 KG
- IDEAL SCREEN SIZE
50"

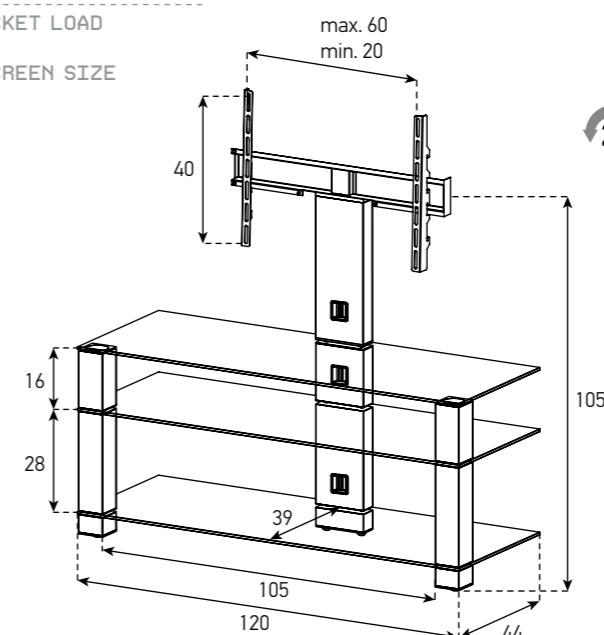

24°



PL 2310-C-SLV

- MAX BRACKET LOAD
50 KG
- IDEAL SCREEN SIZE
50"

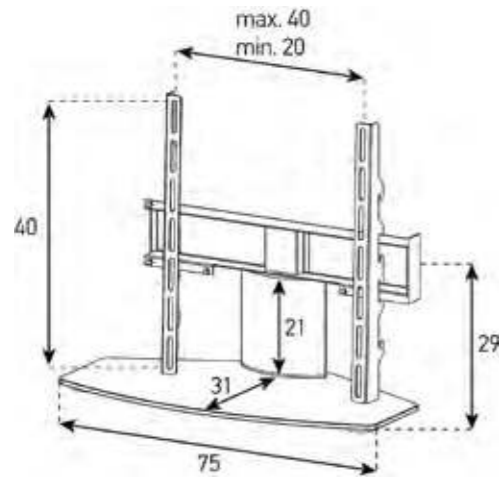

35°



PL 2335-B-HBLK

- MAX BRACKET LOAD
40 KG
- IDEAL SCREEN SIZE
60"

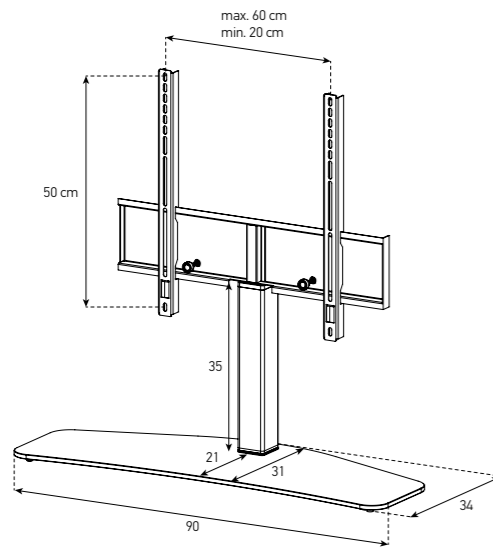

45°



PL 2344-B-HBLK

- MAX BRACKET LOAD
50 KG
- IDEAL SCREEN SIZE
50"

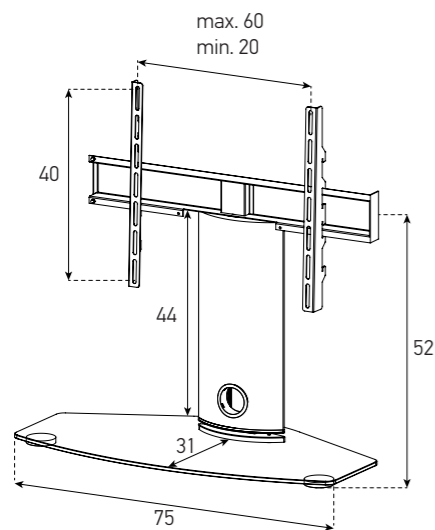

35°



PL 2345-B-HBLK

- MAX BRACKET LOAD
40 KG
- IDEAL SCREEN SIZE
60"

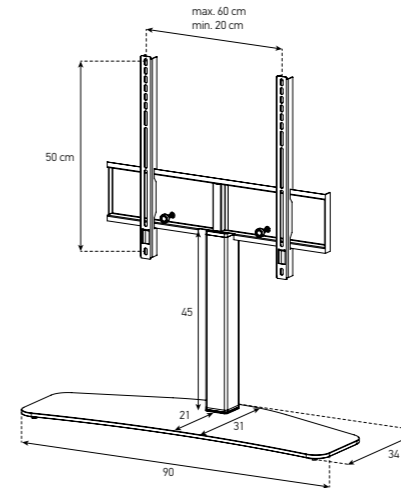

45°



PL 2500-B-INX

- MAX BRACKET LOAD
30 KG
- IDEAL SCREEN SIZE
40"

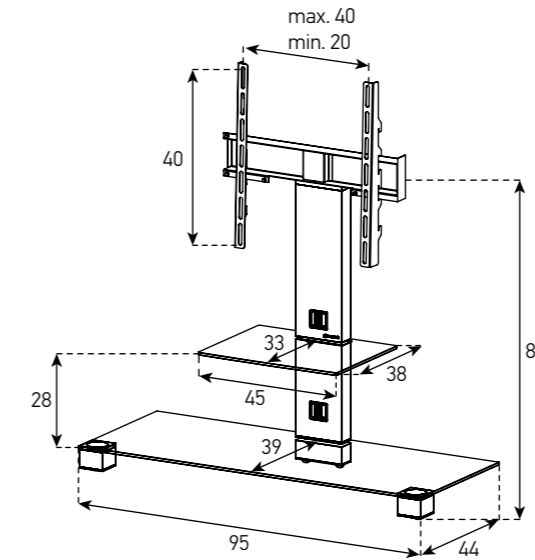

24°



PL 2510-B-INX

- MAX BRACKET LOAD
50 KG
- IDEAL SCREEN SIZE
60"

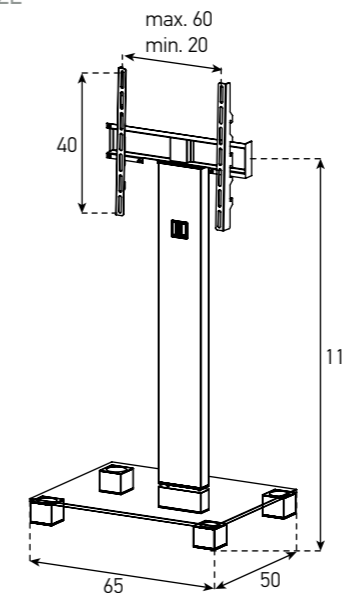

24°



PL 2511-C-INX

- MAX BRACKET LOAD 50 KG
- IDEAL SCREEN SIZE 50"

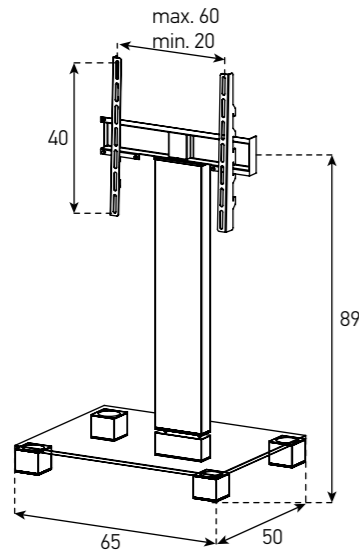

24°



PL 2710-BLK-INX

- MAX BRACKET LOAD 30 KG
- IDEAL SCREEN SIZE 55"

- GLASS COLOR OPTIONS
 WHT-WHITE
 BLK-BLACK
 RED-RED
 GRP-GRAPHITE

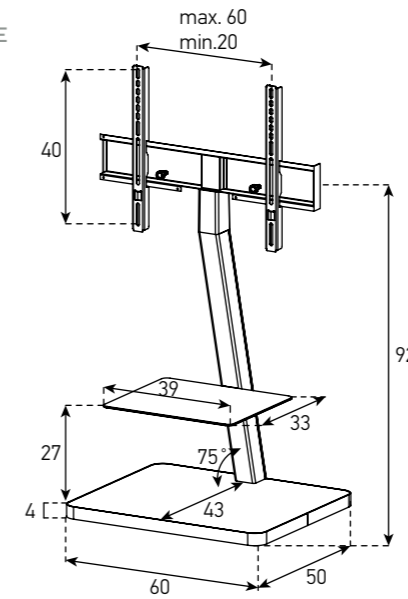

45°



PL 2515-B-HBLK

- MAX BRACKET LOAD 50 KG
- IDEAL SCREEN SIZE 50"

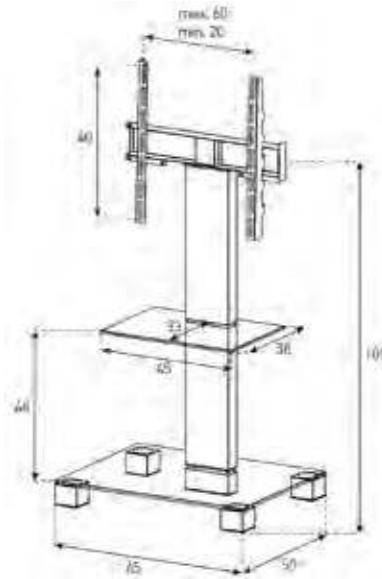

24°



PL 2700-BLK-INX

- MAX BRACKET LOAD 30 KG
- IDEAL SCREEN SIZE 55"

- GLASS COLOR OPTIONS
 WHT-WHITE
 BLK-BLACK
 RED-RED
 GRP-GRAPHITE

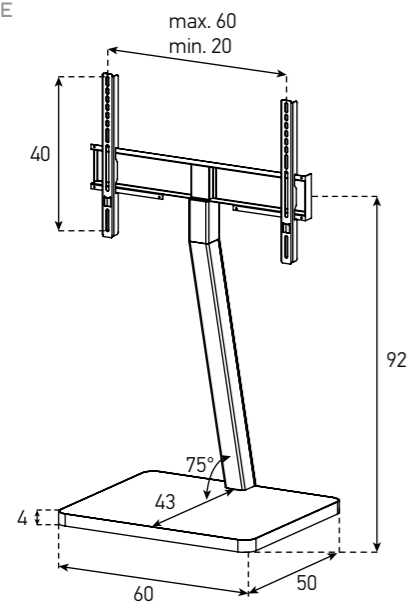

45°



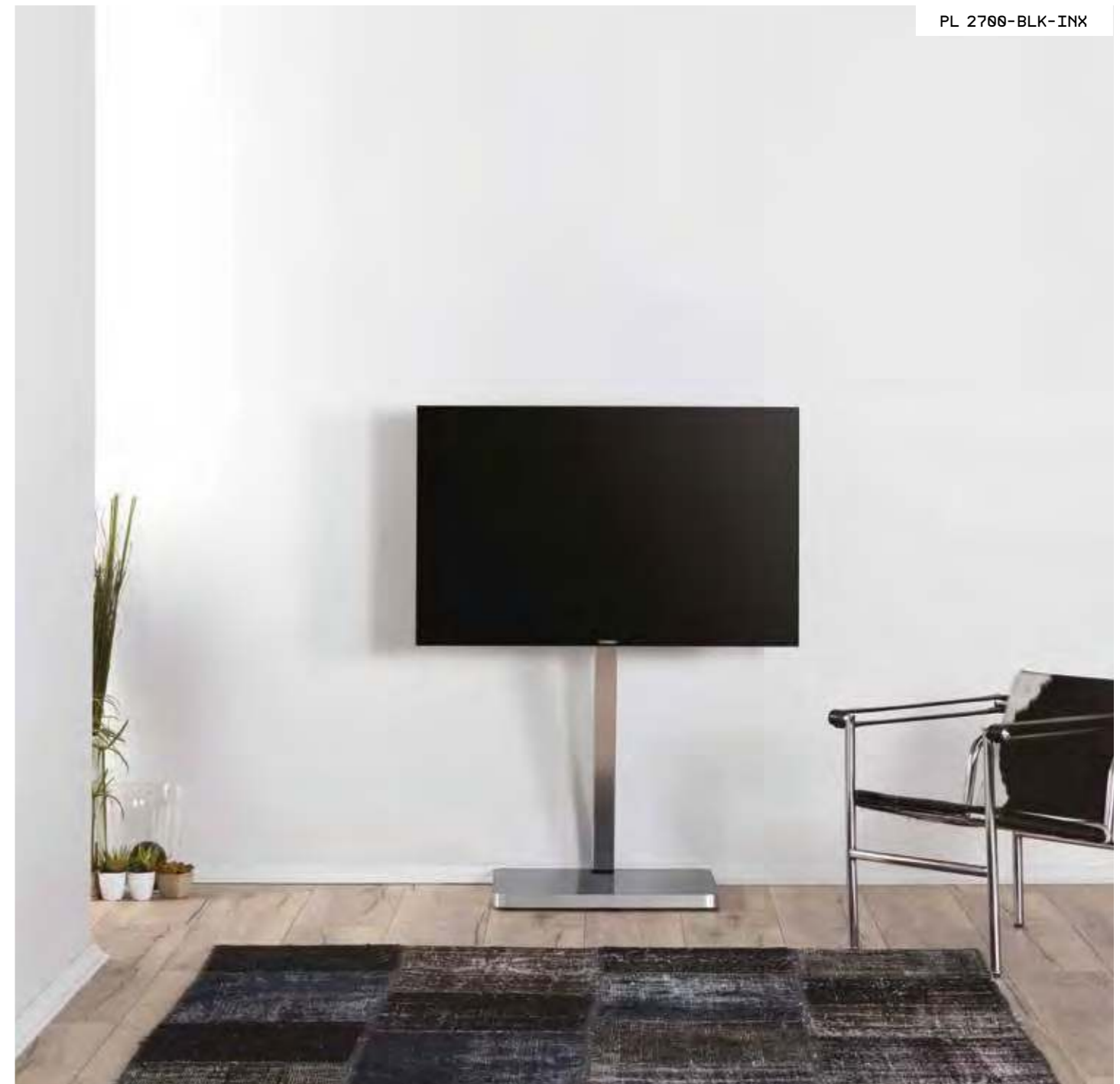

PL 2700-BLK-INX





PL 2710-BLK-INX

PL 2810-BLK

-  MAX BRACKET LOAD
30 KG
-  IDEAL SCREEN SIZE
55"
- GLASS COLOR OPTIONS
WHT-WHITE
BLK-BLACK

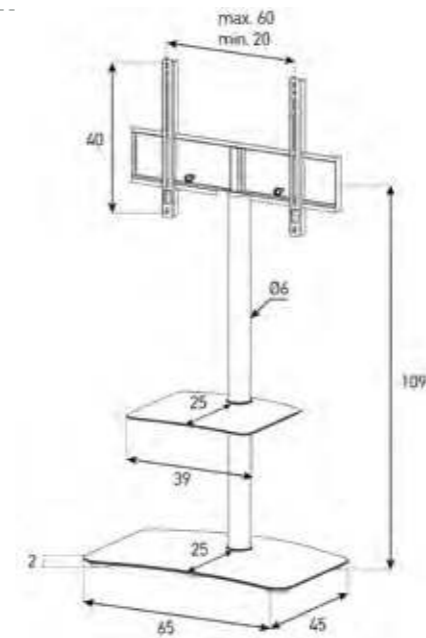

45°



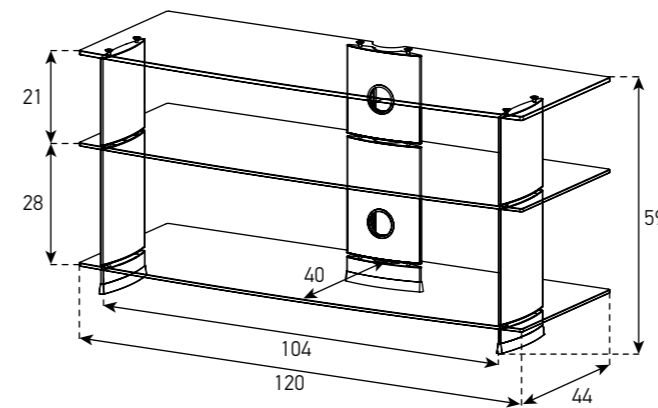

PL 3100-B-SLV

-  MAX TOP LOAD
50 KG
-  IDEAL SCREEN SIZE
50"



PL 2800-WHT

-  MAX BRACKET LOAD
30 KG
-  IDEAL SCREEN SIZE
55"
- GLASS COLOR OPTIONS
WHT-WHITE
BLK-BLACK

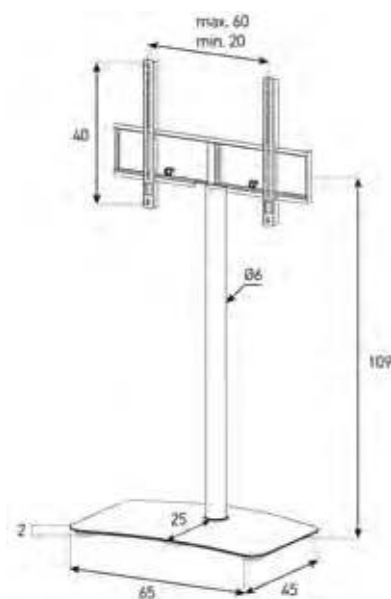

45°



PL 3110-B-SLV

-  MAX TOP LOAD
50 KG
-  IDEAL SCREEN SIZE
50"

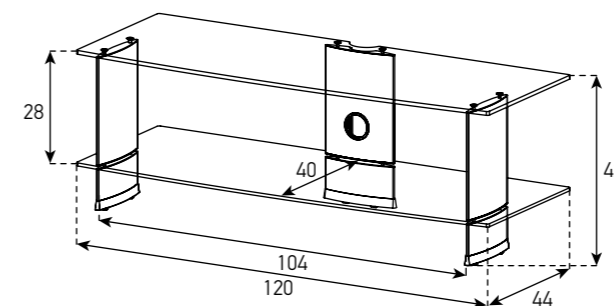

PL 3115-B-HBLK

- MAX TOP LOAD
40 KG
- IDEAL SCREEN SIZE
40"

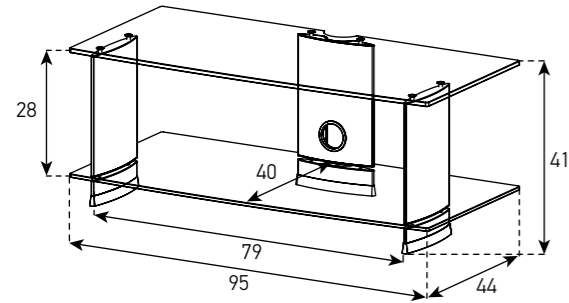

PL 3405-C-INX

- MAX TOP LOAD
40 KG
- IDEAL SCREEN SIZE
40"

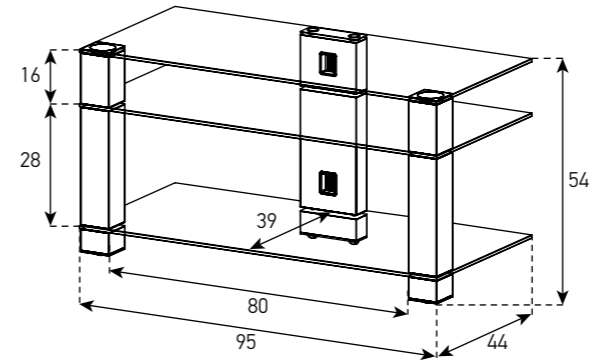

PL 3150-C-SLV

- MAX TOP LOAD
60 KG
- IDEAL SCREEN SIZE
60"

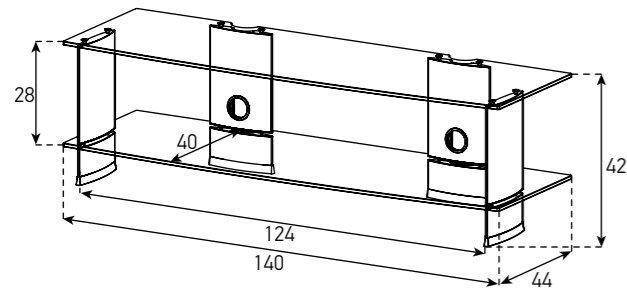

PL 3410-B-HBLK

- MAX TOP LOAD
50 KG
- IDEAL SCREEN SIZE
50"

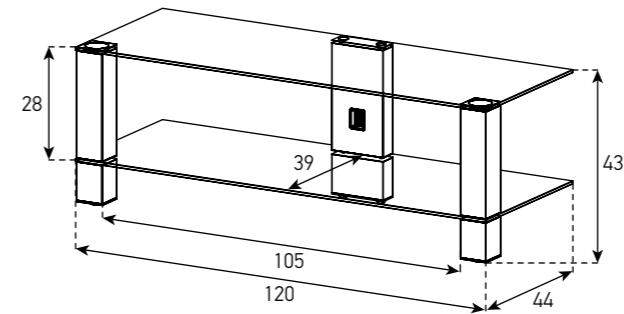

PL 3400-B-INX

- MAX TOP LOAD
50 KG
- IDEAL SCREEN SIZE
50"

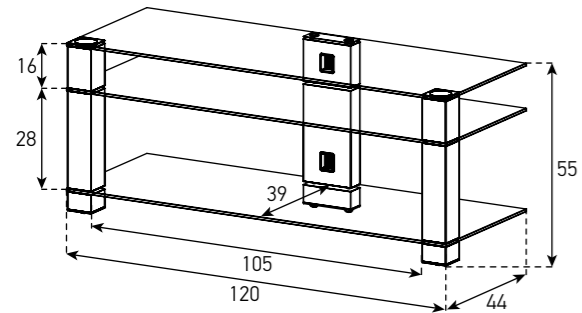

PL 3415-C-INX

- MAX TOP LOAD
40 KG
- IDEAL SCREEN SIZE
40"

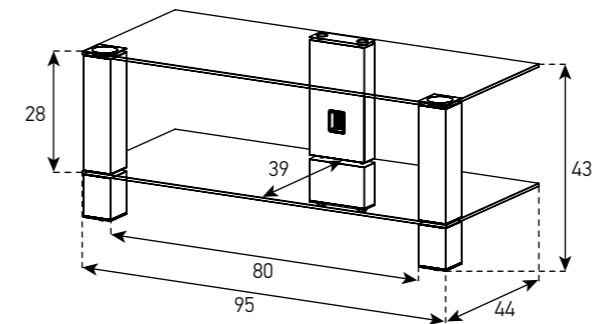

PL 2610-B-BLK

 MAX SHELF LOAD
5 KG

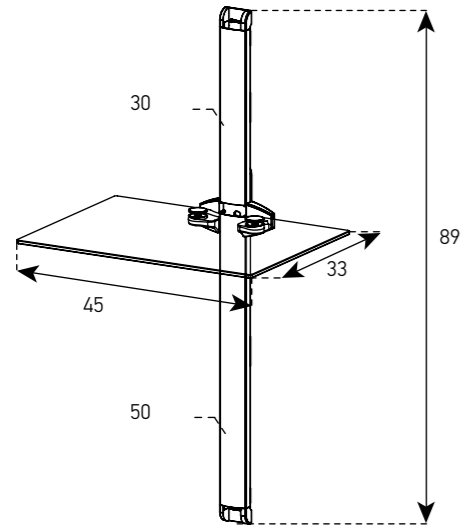

PL 2611-BLK

 MAX LOAD
5 KG

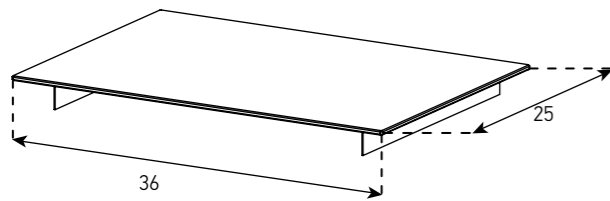

PL 2620-B-SLV

 MAX SHELF LOAD
5 KG

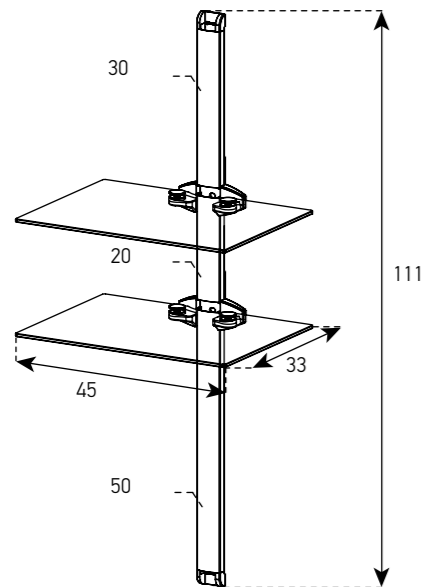

PL 2620-B-SLV

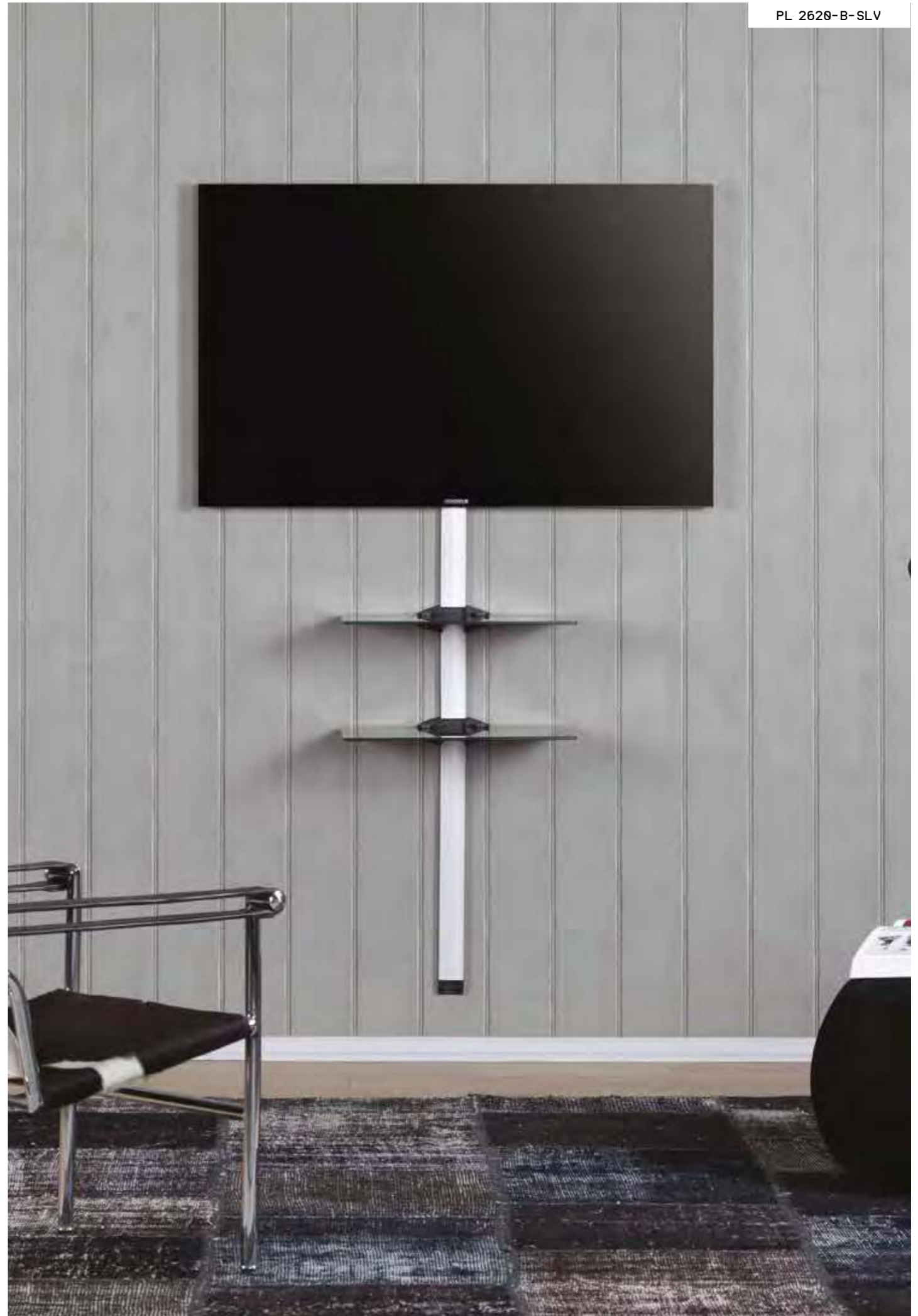

NEO SERIES

SPECIFICATIONS

- TEMPERED GLASS WITH FLAT POLISHED EDGE
- CYLINDRICAL AND ELLIPTICAL SHAPED ALUMINIUM PROFILES
- INTEGRATED CABLE MANAGEMENT SYSTEM
- HIDDEN CASTERS

| | | | | |
|----------|----------|---------|---------|----------|
| NEO 270 | NEO 370 | NEO 80 | NEO 95 | NEO 953 |
| NEO 290 | NEO 390 | NEO 81 | NEO 110 | NEO 1103 |
| NEO 2110 | NEO 3110 | NEO 803 | NEO 130 | NEO 1303 |

GLASS COLORS

C-CLEAR



ALUMINIUM COLORS

SLV-SILVER



HBLK-HIGH GLOSS BLACK



B-BLACK



NEO 270-C-SLV

- MAX TOP LOAD
50 KG
- IDEAL SCREEN SIZE
32"

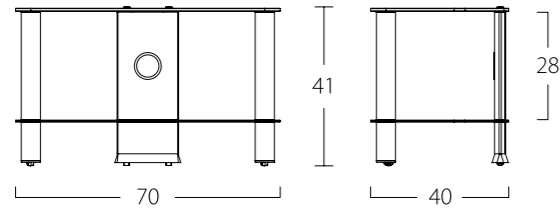

NEO 370-B-SLV

- MAX TOP LOAD
50 KG
- IDEAL SCREEN SIZE
32"

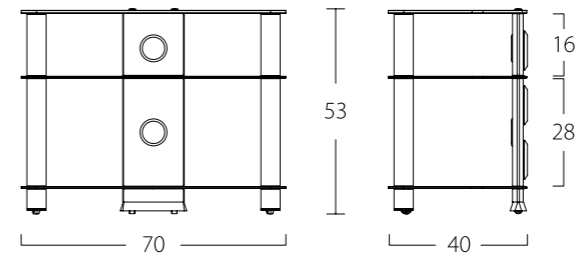

NEO 290-B-HBLK

- MAX TOP LOAD
50 KG
- IDEAL SCREEN SIZE
40"

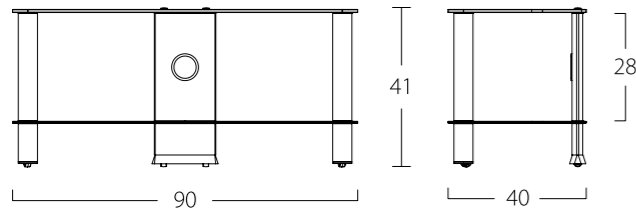

NEO 390-B-HBLK

- MAX TOP LOAD
50 KG
- IDEAL SCREEN SIZE
40"

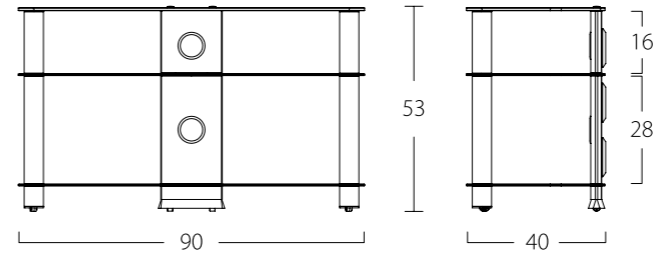

NEO 2110-B-SLV

- MAX TOP LOAD
50 KG
- IDEAL SCREEN SIZE
46"

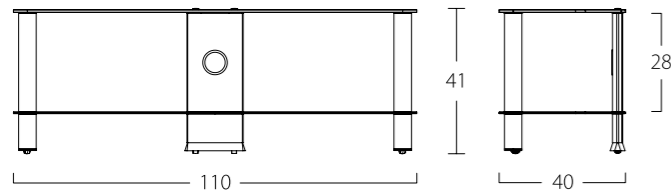

NEO 3110-B-HBLK

- MAX TOP LOAD
50 KG
- IDEAL SCREEN SIZE
46"

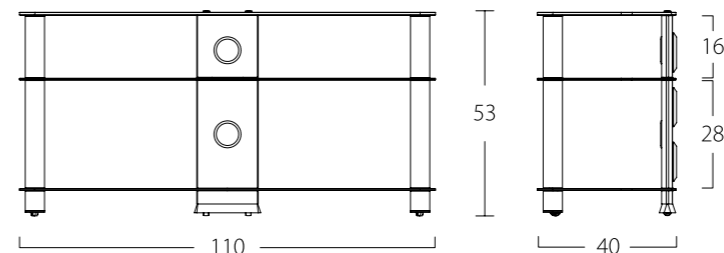

NEO 3130-B-HBLK

- MAX TOP LOAD
50 KG
- IDEAL SCREEN SIZE
55"

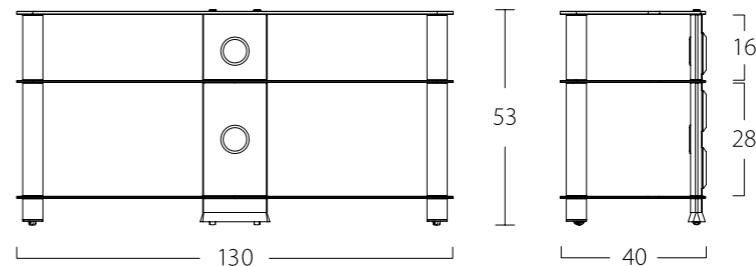

NEO 80-B-SLV

- MAX BRACKET LOAD
30 KG
- IDEAL SCREEN SIZE
32"

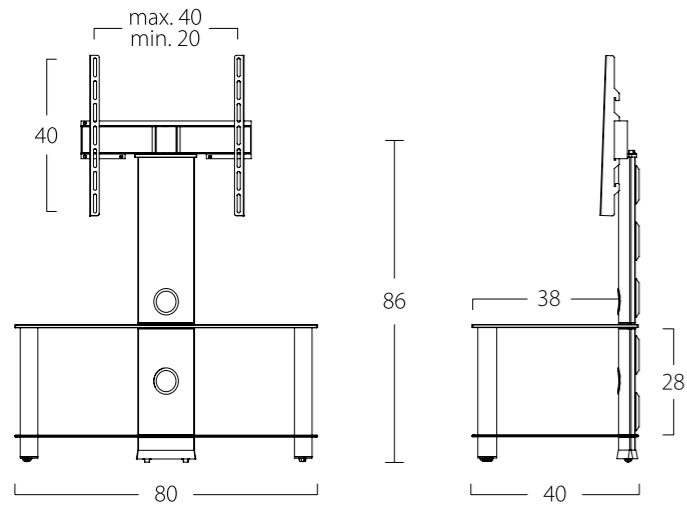

NEO 95-B-HBLK

- MAX BRACKET LOAD
40 KG
- IDEAL SCREEN SIZE
40"

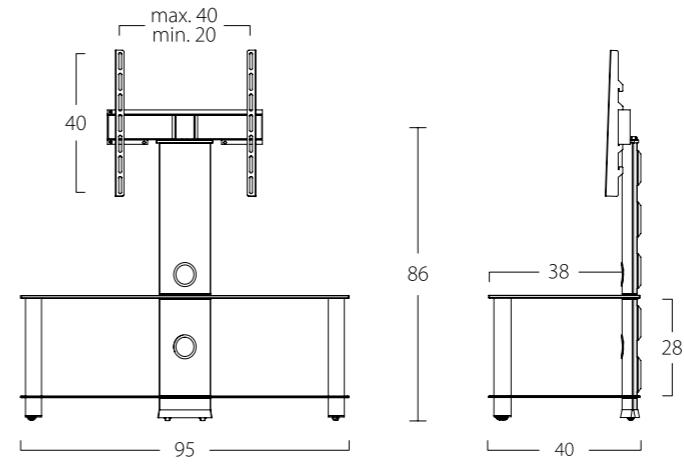

NEO 81-C-SLV

- MAX BRACKET LOAD
30 KG
- IDEAL SCREEN SIZE
32"

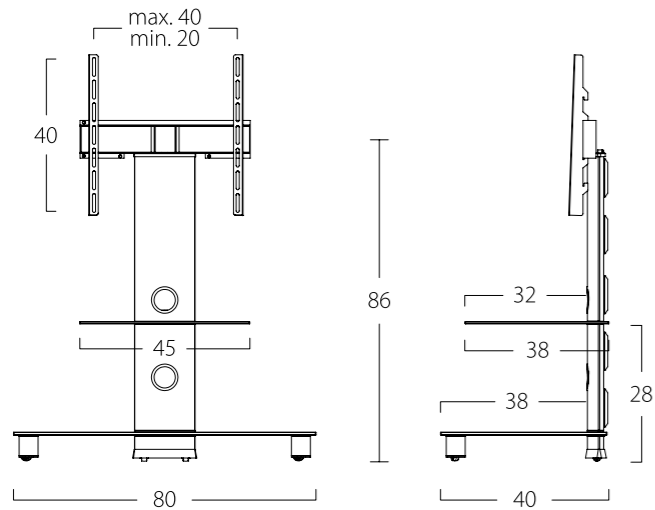

NEO 110-C-SLV

- MAX BRACKET LOAD
40 KG
- IDEAL SCREEN SIZE
46"

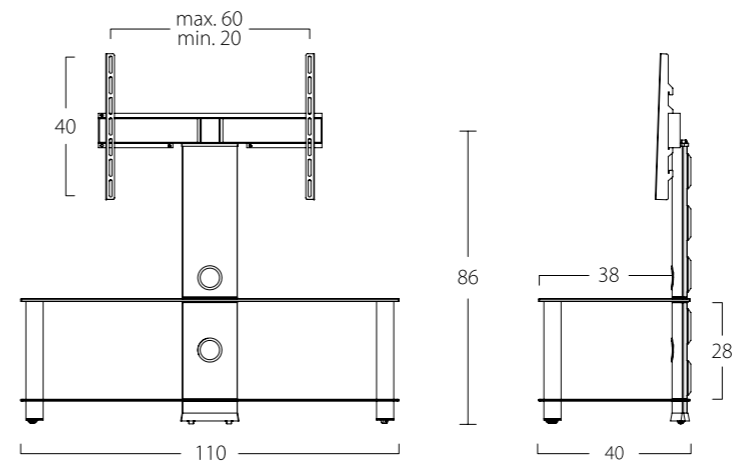

NEO 803-B-SLV

- MAX BRACKET LOAD
40 KG
- IDEAL SCREEN SIZE
32"

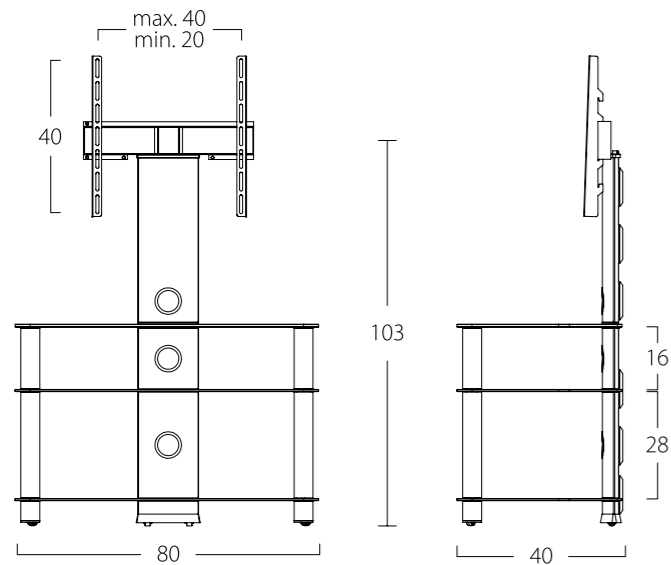

NEO 130-B-SLV

- MAX BRACKET LOAD
40 KG
- IDEAL SCREEN SIZE
55"

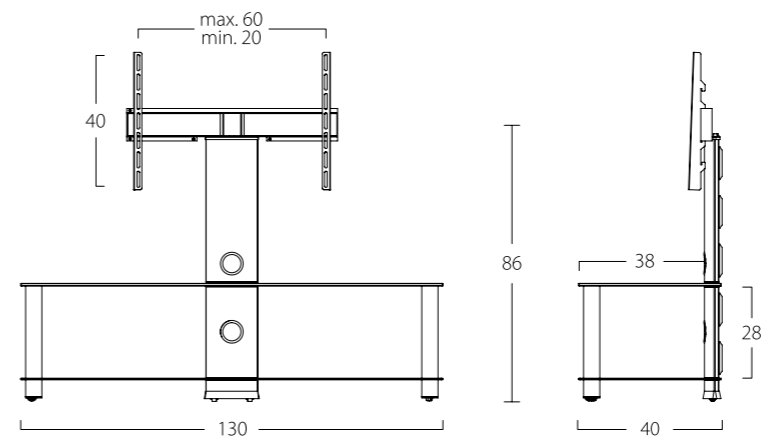

NEO 953-B-SLV

MAX BRACKET LOAD
40 KG

IDEAL SCREEN SIZE
40"

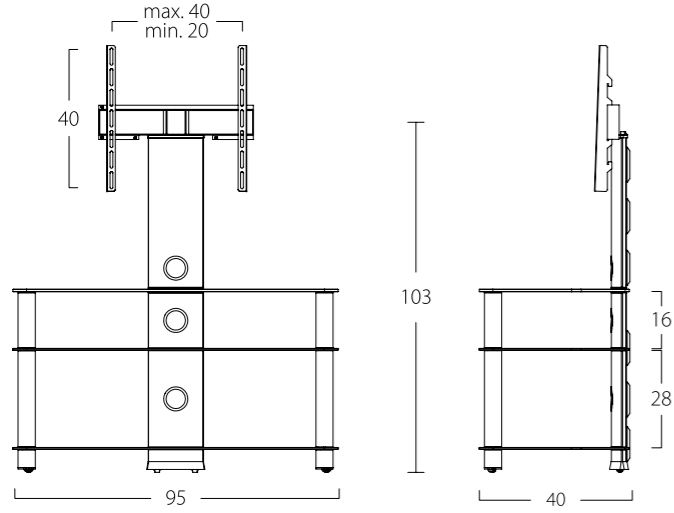

NEO 1103-B-SLV

MAX BRACKET LOAD
40 KG

IDEAL SCREEN SIZE
46"

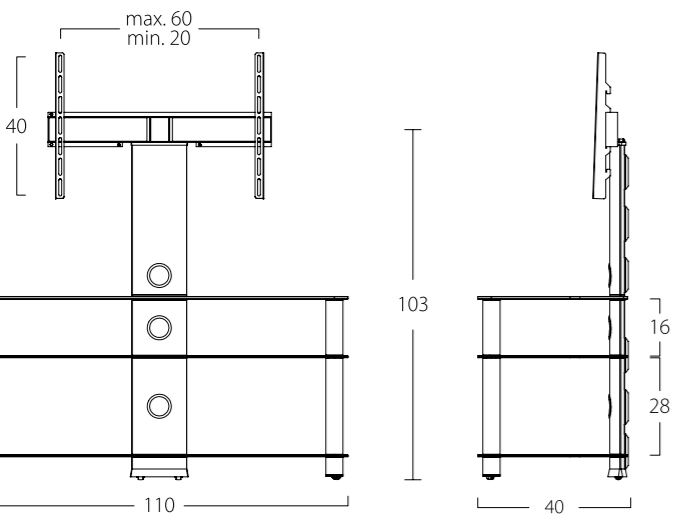

NEO 1303-B-BLK

MAX BRACKET LOAD
40 KG

IDEAL SCREEN SIZE
55"

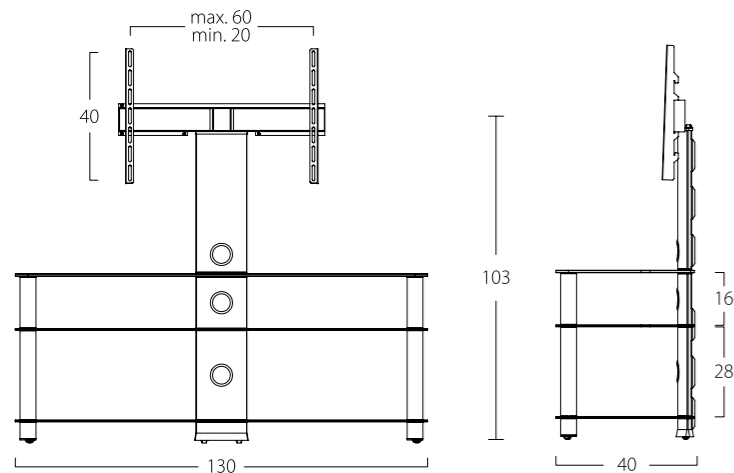

SOUND SYSTEMS

ROXY

TEMPERED GLASS WITH FLAT POLISHED EDGE
 Ø 60 MM AND ELLIPTICAL SHAPED ALUMINIUM
 SQUARE SHAPED ALUMINIUM AND HIDDEN WHEELS FOR RX 5040
 INTEGRATED CABLE MANAGEMENT SYSTEM (NOT AVAILABLE FOR RX 5040)

SPEAKER

UNIVERSAL COMPATIBILITY
 ADJUSTABLE HEIGHT (FOR SP 300)

RX 2130 SP 100¹
 RX 2140 SP 200
 RX 2150 SP 300
 RX 5040² SP 500
 RX 6040³ SP 600

ALUMINIUM COLORS

SLV-SILVER



HBLK-HIGH GLOSS BLACK

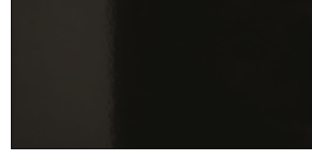

INX-INOX



GLASS COLORS

C-CLEAR



B-PIANOBLACK



WHT-WHITE



WOOD COLORS

VIC-VICTORIA



METAL COLORS

BLK-BLACK



WHT-WHITE



RX 2140-C-SLV
 SP 100-BLK



RX 5040-B-INX
 SP 100-BLK

RX 2130-B-HBLK

MAX TOP LOAD
40 KG

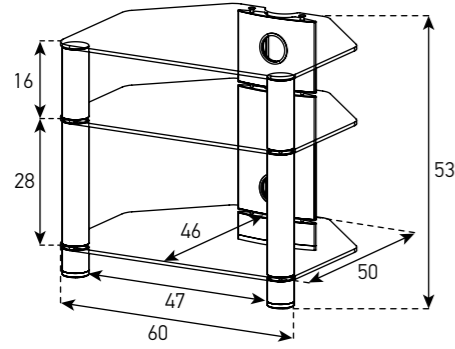

RX 5040-B-INX

MAX TOP LOAD
40 KG

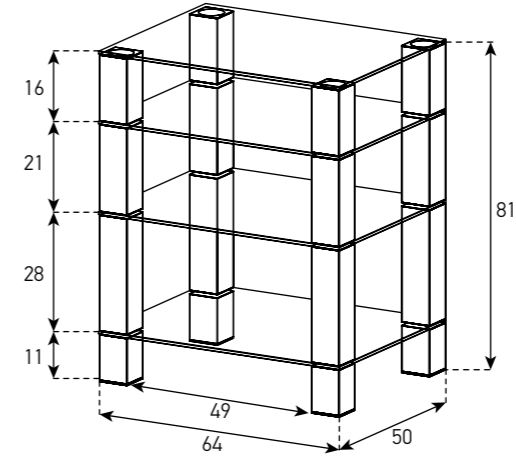

RX 2140-B-SLV

MAX TOP LOAD
40 KG

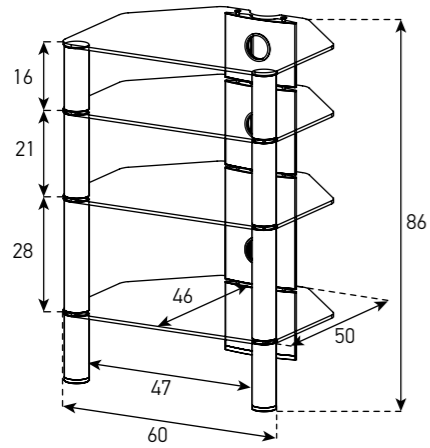

RX 5040-VIC-HBLK

MAX TOP LOAD
40 KG

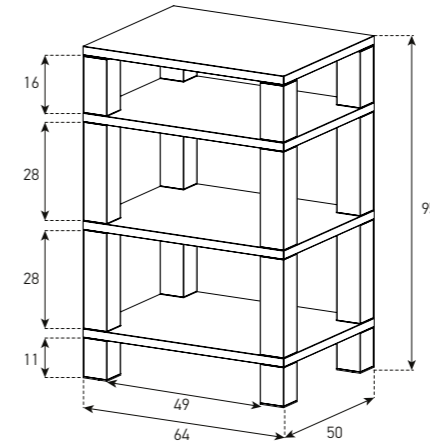

RX 2150-C-SLV

MAX TOP LOAD
40 KG

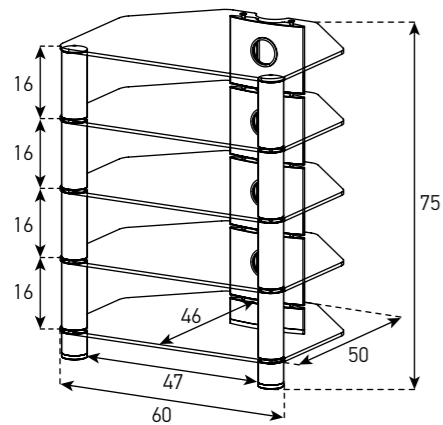

RX 6040-B-HBLK

MAX TOP LOAD
40 KG

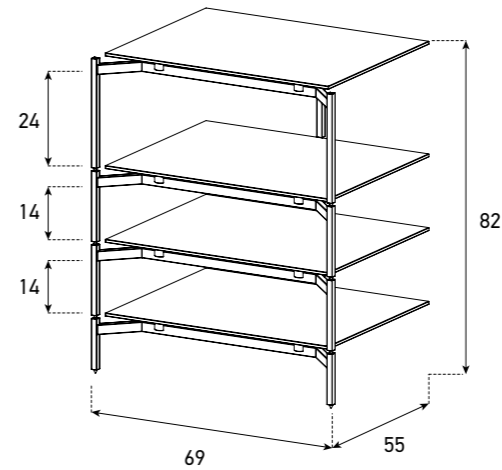

RX 6040-VIC-HBLK

MAX TOP LOAD
40 KG

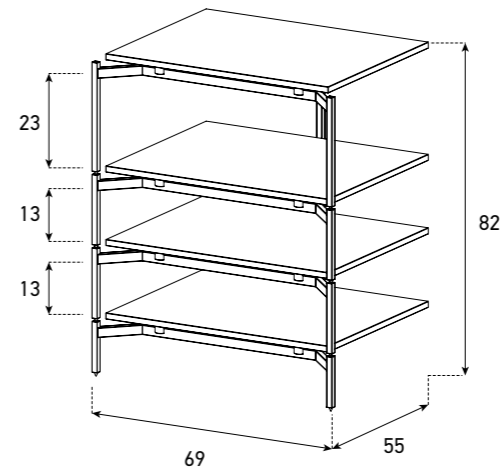

SP 100-B-HBLK

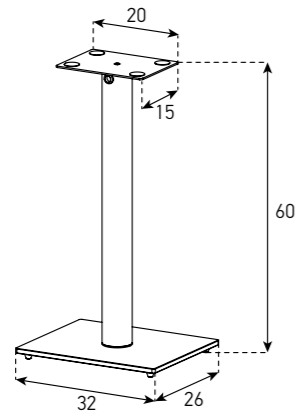

SP 300-B-HBLK



SP 100-WHT-WHT

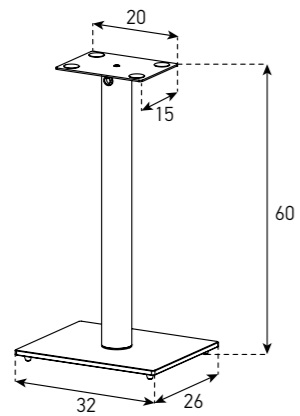

SP 500-BLK

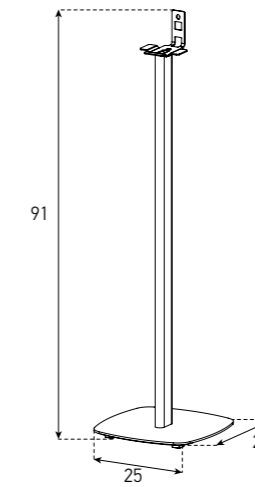

SP 200-B-SLV

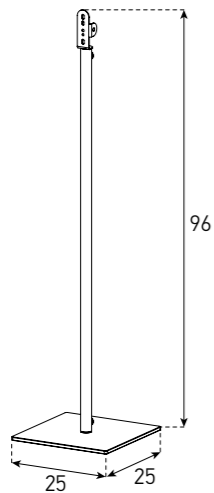

SP 600-B-HBLK

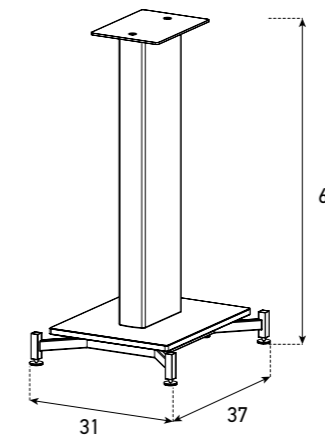

PROFFESIONAL SERIES

PR 2000

- 360° EASY-MOVE CASTORS (LOCKING OPTION)
- CABLE MANAGEMENT
- ADJUSTABLE HEIGHT WITH TELESCOPIC POLES (50 CM FLEXIBILITY)
- AV TRAY FOR ELECTRONIC DEVICES
- WIDE MOUNTING PATTERN, 90° ROTATION 2 OPTIONS FOR TV POSITION (LANDSCAPE /PORTRAIT)
- TV HEIGHT ADJUSTMENT MIN. 100 CM, MAX 150 CM.
- UPPER VIDEO TRAY SUPPORT (PROJECTOR / CONFERENCE CALL CAMERA)

PR 2550

- TEMPERED GLASS WITH FLAT POLISHED EDGE
- RECTANGLE SHAPED ALUMINIUM
- INTEGRATED CABLE MANAGEMENT SYSTEM
- HIDDEN CASTERS
- (24°) SWIVEL SYSTEM
- ADJUSTABLE HEIGHT FOR BRACKET

PR 2000-N¹
PR 2550²

ALUMINIUM COLORS

HBLK-HIGH GLOSS BLACK



INX-INOX



GLASS COLORS

C-CLEAR



B-PIANOBLACK



METAL COLORS

BLK-BLACK



PR 2000-N

- MAX BRACKET LOAD
45 KG
- IDEAL SCREEN SIZE
65"

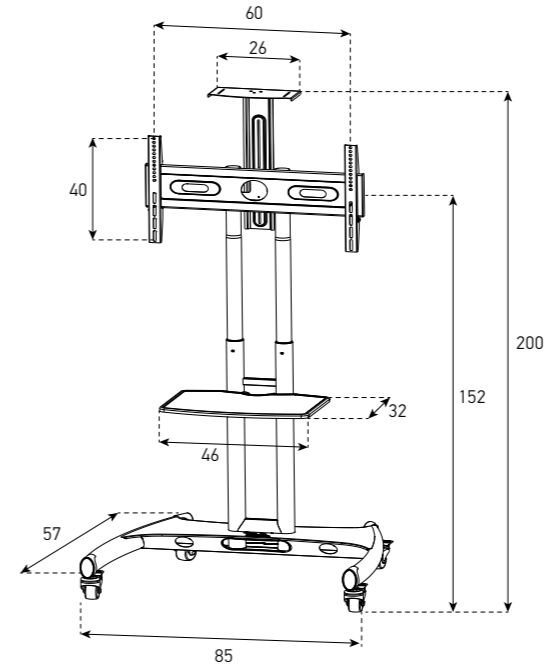

PR 2550-B-HBLK

- MAX BRACKET LOAD
50 KG
- IDEAL SCREEN SIZE
50"

